

# NAV-TV

INTERFACING THE FUTURE

3950 NW 120<sup>th</sup> Ave, Coral Springs, FL 33065 TEL 561-955-9770 FAX 561-955-9760

## UCTv2 +

Dodge/Jeep uConnect (RA3/RA4) Dual Camera & A/V Interface

NTV-KIT763



## Overview

The UCTv2 series Interface integrates multiple video inputs to the factory 8.4" touch screen in compatible 2013+ Dodge and Jeep vehicles, with additional expansion options for future upgrades.

**UCTv2 (KIT762):** Add up to 2 additional inputs (or 1 input while retaining OEM camera).

**UCTv2+ (KIT763):** Same functionality as the standard system but includes an AVSW for audio integration (AV input).

**UCTv2 MULTI-CAM (KIT764):** Same functionality as the standard system but includes a data-controlled SVS-6 switcher capable of adding 6 additional video inputs all while retaining any existing OEM cameras.

**NOTE:** The UCTv2 MULTI-CAM kit is **required** for RAMs that have an OEM Cargo Camera or to emulate the Cargo Camera menu.

## Kit Content

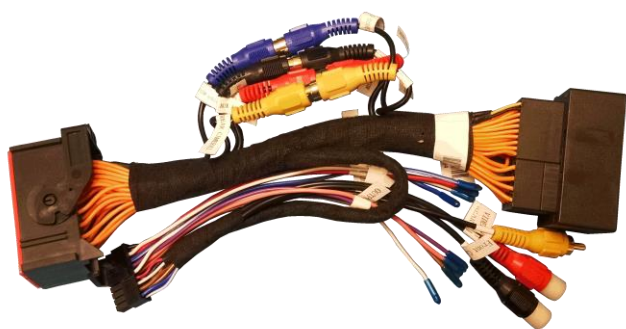

Plug & Play T-harness  
NTV-HAR246/264



UCTv2+ Module (KT2)  
NTV-ASY245



USB Cable (updates)  
NTV-CAB009

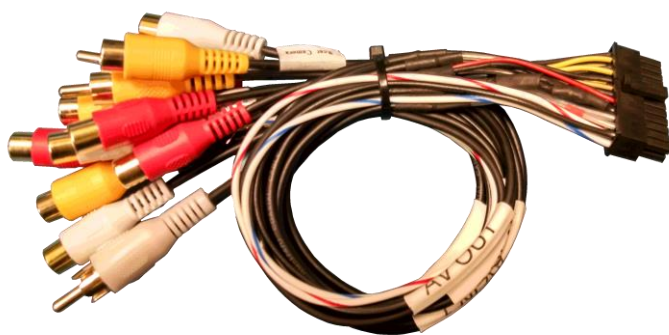

Power/Trigger Harness  
NTV-HAR293



AVSWv2 module  
NTV-ASY255

UCTv2 + pin out

PIN #	Description	Color
1	12v (+) Constant	Yellow
2	INPUT 1: VIM Activation*	Red
3	--NOT USED--	Blue
4	INPUT 3: Front CAM/Cargo Cam (selectable)	Pink
5	RX (not present)	--
6	RCA MALE	--
7	RCA Shield	--
8	CAN HI (Radio Side)	Brown/White
9	CAN HI (Car Side)	Blue/White
10	Ground (-)	Black
11	OUTPUT 1 Provides 12v (+) ACC OUT	White/Red
12	OUTPUT (2) when AUX is activated (AVSW V1 Trigger)	Blue/White
13	OUTPUT (3) when Front CAM is activated (AVSW V2 Trigger)	Purple
14	TX INPUT (UART control to SVS-6 RX)	White/Brown
15	RCA Female (Normally Open)	--
16	RCA Female (Normally Closed)	--
17	CAN LO (Radio Side)	Brown
18	CAN LO (Car Side)	Blue

OUTPUTs 2 & 3 send 12v (+) with corresponding button press (force cam)

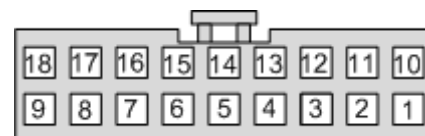

Wire Side

\*Not supported on all models

RA3/RA4 Radio LCD connector pin out

Pin #	Description	Color
2	CAN HIGH	Dark Blue
12	CAN LOW	White
31	Diff Video (-)	Green/Brown
32	Diff Video (+)	Green/Orange
33	Shield	
43	Ground	Black
44	Constant 12v	Red

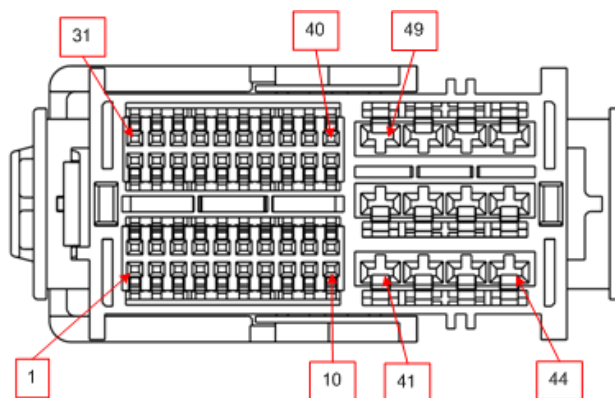

PIN Side

## Dash Disassembly (basic RAM)

1. Remove the Torx t20 screw at the right rear of the pocket on the right side of the dash.



2. Remove (2x) Torx t20 at the top of the dash. They are hidden beneath a rubber mat.



3. The face should be free now, pull straight outwards (towards you) with medium force. Use plastic panel tools if necessary.



4. Remove (4x) 7mm screws that secure the LCD touchscreen.



UCTv2 + Module Installation

1. After removing the factory radio, grab the provided **Plug & Play T-harness** and connect the female side to the factory 44-pin plug. Make certain the lock connects together securely.
2. Install A/V source and run signal/power leads into the front dash opening. **Note:** 12v ACC is provided from **output 1** (PIN 11, white/red). ***If connecting any device(s) which draw 1amp or more, trigger a relay with this output instead powering directly!***
3. Make all connections (RCAs & wired) as shown in diagram below (if adding A/V source only) **OR** page 6 (if adding A/V source AND Front camera).
4. Connect the male side of the **Plug & Play T-Harness** to the main radio display. Proceed to page 9 for programming.



UCTv2 + Install Diagram (adding A/V with OEM tailgate camera)

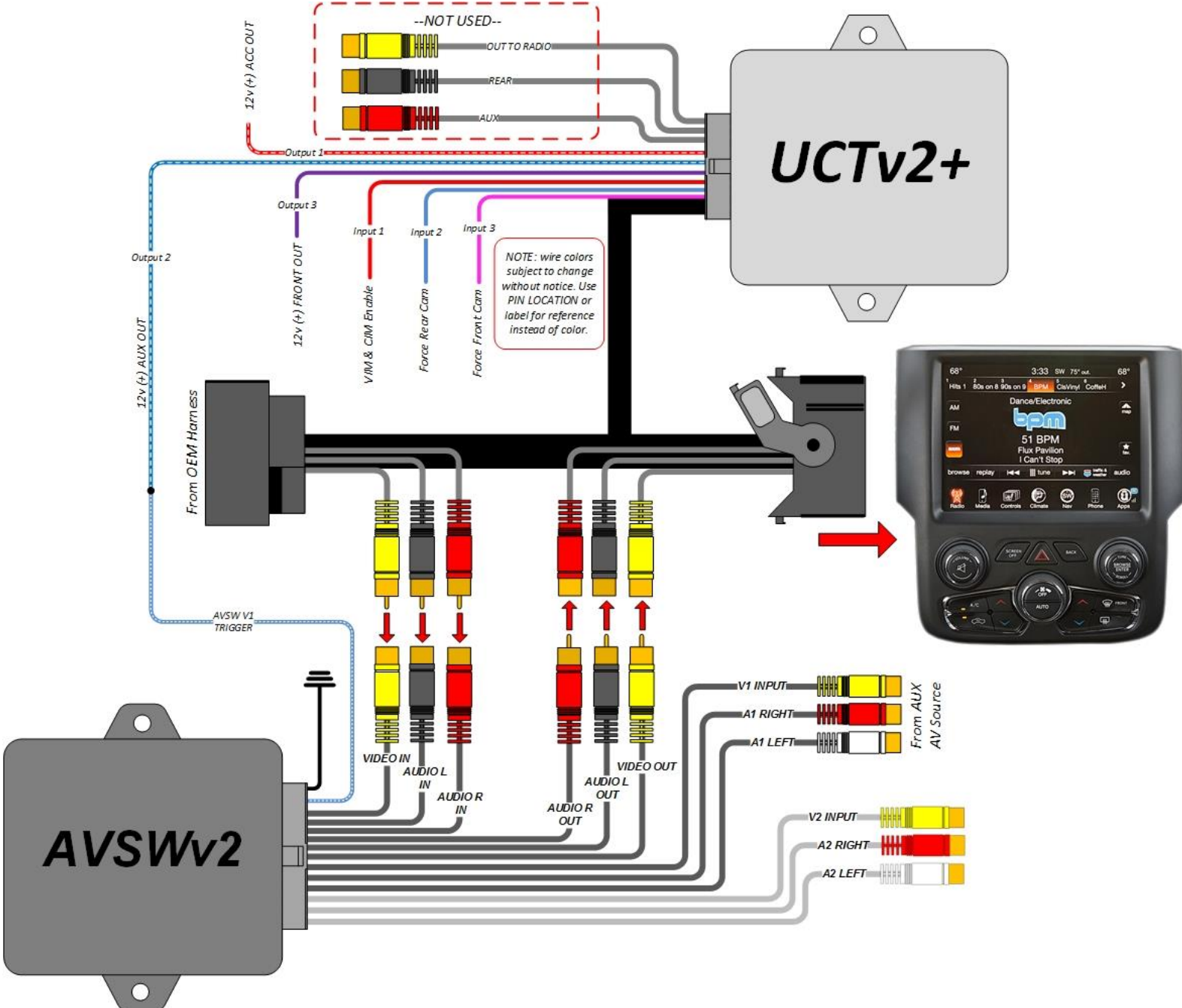

UCTv2 + Install Diagram (adding A/V & Front CAM with OEM tailgate camera)

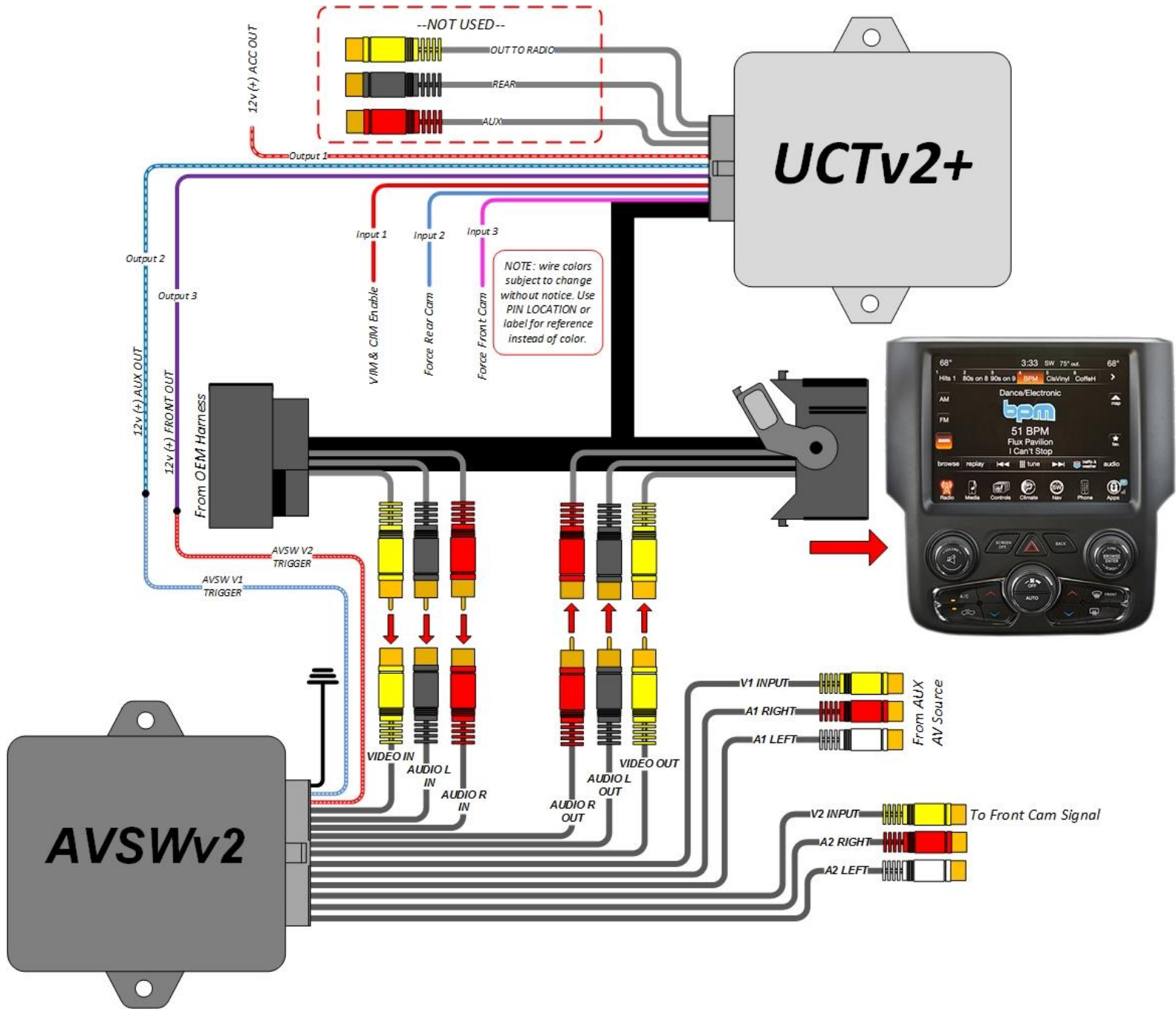

Agreement: End user agrees to use this product in compliance with all State and Federal laws. NAV-TV Corp. would not be held liable for misuse of its product. If you do not agree, please discontinue use immediately and return product to place of purchase. This product is intended for off-road use and passenger entertainment only.

## UCTv2 + Programming

**Programming the UCTv2 + is performed in the vehicle, through the factory dash MUTE button, TUNING KNOB, and CLUSTER LCD for feedback.**

Press and HOLD  
(15 seconds)  
to enter NAV-TV  
settings mode



While in NAV-TV  
settings mode only:  
Rotate clockwise  
(**slowly**, one  
detent/time) to  
scroll through  
options. Press ENTER  
to change setting.

1. Before attempting to program, after making connections, let the vehicle perform a CAN-reset: Close all doors/trunk/hood, lock the vehicle and waiting 10 minutes before proceeding to program.
2. Turn the vehicle's ignition on. Be certain you're resting in **FM mode** (see an FM station frequency on the cluster), otherwise the cluster information may not display.



To show the FM source on the **cluster**, first clear any messages shown (door status, etc) with the UP or DOWN arrows on the steering wheel. Press the audio source button until 'FM' is displayed.

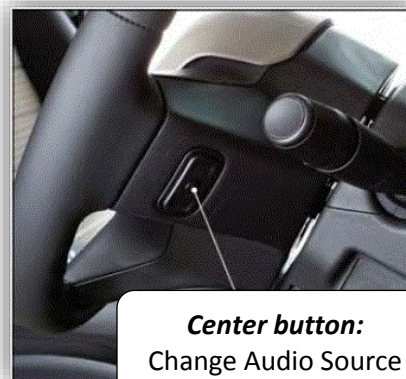

**Center button:**  
Change Audio Source

3. Close all doors (*door status may override NAV-TV settings cluster feedback*).
4. View the chart on the next page for settings descriptions and the diagram above to begin programming.
5. NAV-TV programming mode will time out (back to factory) after 15 seconds. **Scroll to the end of the settings menu and select 'EXIT' to exit and save settings.**

UCTv2 + Programming Parameters (OEM Cluster)

Parameter (cluster)	Adjustment Options	Description
NAV-TV Settings	TUNE-Next Item / Enter Change	Rotate TUNE knob to access different menus, press knob inwards to enter/change setting
GEAR	AUTO / STICK	<b>AUTO:</b> Select this option if the vehicle has an automatic transmission <b>STICK:</b> Select this option if the vehicle has a manual transmission
SWITCH	RELAY / AVSW / SVS-6	<b>RELAY:</b> Uses RCA inputs on the UCTv2 module itself (UCTv2) <b>AVSW:</b> Select when using AVSW board (UCTv2+) <b>SVS-6:</b> Select when using SVS-6 switcher (UCTv2 MULTI-CAM)
RVC	OEM / AFTERMARKET / OFF	<b>OEM:</b> Vehicle has a manufacturer-installed reverse camera. <b>AFTERMARKET:</b> Any aftermarket reverse camera. <b>OFF:</b> Choose if not adding a reverse tailgate camera.
F. RVC	OFF / ON	<b>ON:</b> Enables option of forcing rear view camera.*
FRONT CAM	OFF / ON / <8	<b>ON:</b> Enables option of installed front camera. <b>&lt;8:</b> Front camera will display between 1-8 MPH.
AUX VID	OFF / ON	<b>ON:</b> Enables option of AUX VIDEO
TURN S	<b>AVAILABLE WITH ADDITIONAL HARDWARE. See NTV-KIT764 (UCTv2 MULTI-CAM)</b>	
Cargo CAM**		
INPUT3		
EXIT		



The **SWITCH** you choose determines which options will display on the cluster, to reduce confusion.

Option color	SWITCH chosen:
	ANY
	AVSW
	---

\*Factory Rear camera is controlled via LIN. Forced OEM RVC is not supported with the UCTv2.



## Programming for 2016+ Vehicles equipped with Panasonic Radios (CarPlay/Android Auto)

*NOTE: this procedure is NOT required if the vehicle has an OEM reverse camera installed.*

- For 2016+ vehicles equipped with the new Panasonic radio, if adding a rear camera, the method for activating rear-camera has changed and requires additional (startup/shut down) steps. Follow the procedure below **after programming desired options in the NAV-TV cluster menu** in these vehicles:
  1. Open the driver's door and leave it open until step 4.
  2. After Installing the kit and adjusting the menu for desired options, shut down the vehicle with the key (or push button). **Wait for the LED on the module to go out – the CAN bus must remain undisturbed for 2 minutes at this point (starting from after the LED is out).**
  3. Turn the vehicle on and wait for the radio to boot fully (able to control volume/adjust radio). **Wait 1 minute with normal operation.**
  4. Turn the car off and perform a **full CAN reset**: Close all the doors, lock the car with the remote and walk away for at least 10 minutes. *Do not disturb the car whatsoever for 10 minutes.*
  5. Return to the vehicle and start the car (run), place the vehicle into reverse to verify that the system received the programming.

*For further information on this process and video reference, see our YouTube video here:*

<https://www.youtube.com/watch?v=XOtkOUCLXik>

UCTv2 + Force Buttons

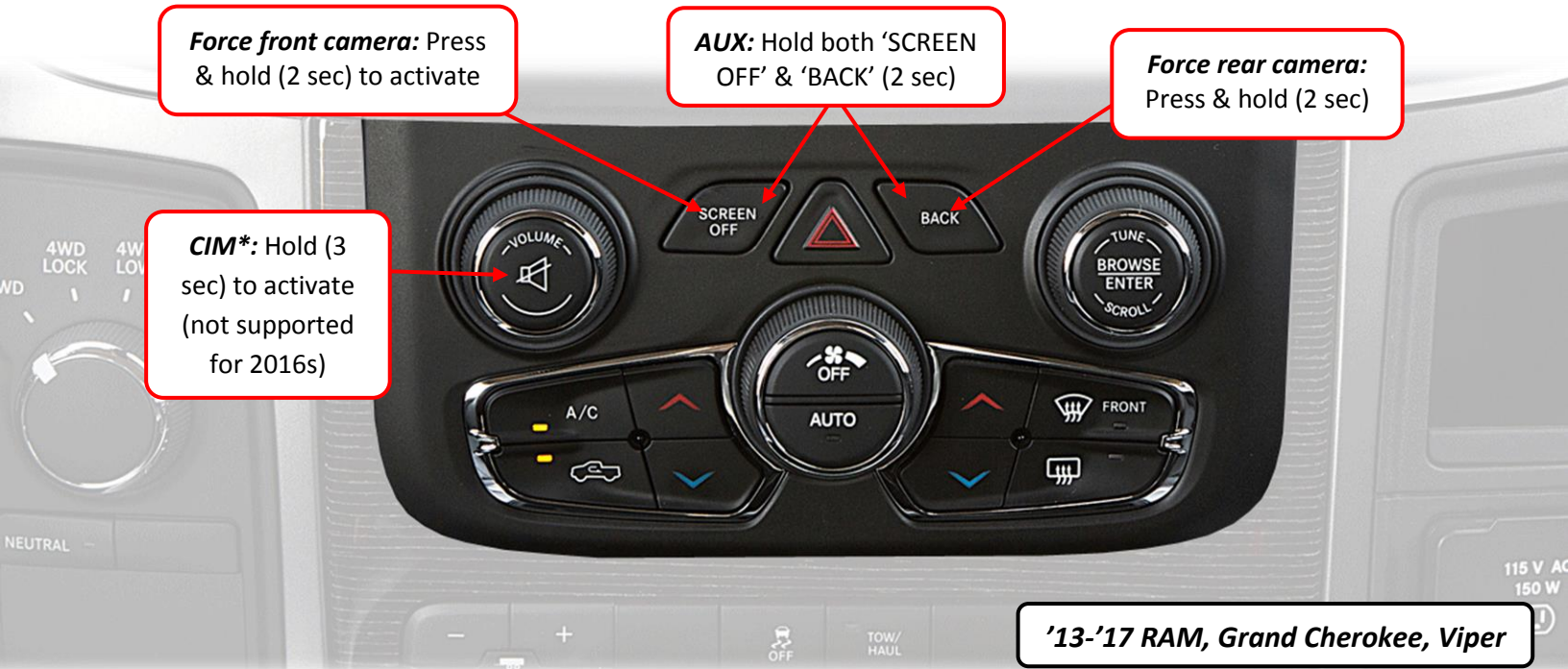

\*Not supported on all models



\*Not supported on all models

Agreement: End user agrees to use this product in compliance with all State and Federal laws. NAV-TV Corp. would not be held liable for misuse of its product. If you do not agree, please discontinue use immediately and return product to place of purchase. This product is intended for off-road use and passenger entertainment only.

UCTv2 + Camera Force Buttons (continued)

- For 2016 & 2017 SRT vehicles, the radio has changed and is clearly indicative by the radio control buttons or the GUI on the touch panel. For these vehicles, use the following buttons to force video sources:

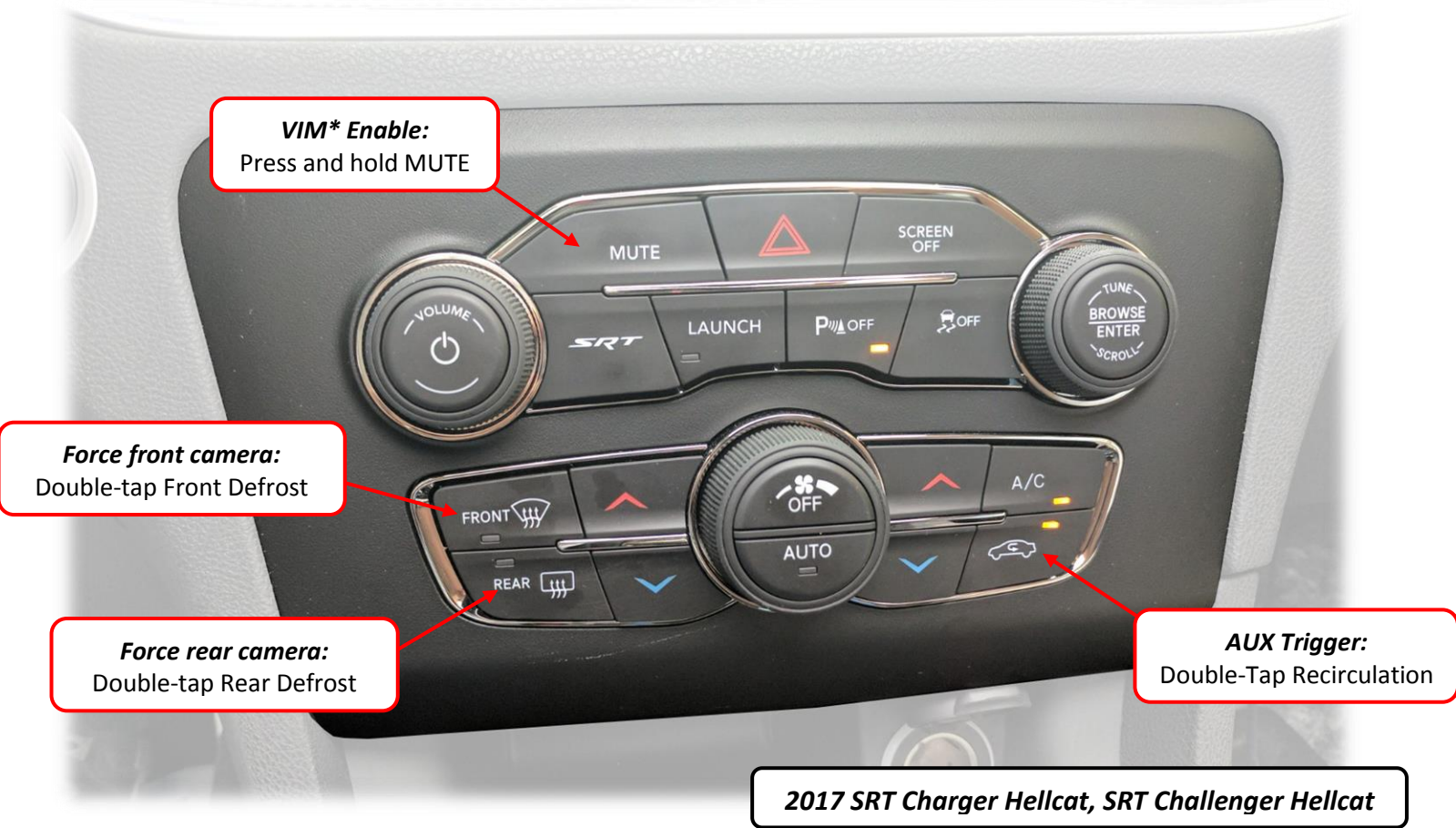

*\*Not supported on all models*

Agreement: End user agrees to use this product in compliance with all State and Federal laws. NAV-TV Corp. would not be held liable for misuse of its product. If you do not agree, please discontinue use immediately and return product to place of purchase. This product is intended for off-road use and passenger entertainment only.

UCTv2 + Operation Information

**Rear Camera Operation:** Placing the vehicle in to reverse will automatically display any connected camera. This image will take precedence over all other images.

**Force Rear Camera:** To force rear camera, press and hold radio **'BACK'** button for 2 seconds. To exit forced rear camera, press and release radio **'BACK'** button. **Note:** *forced rear camera is only supported on aftermarket cameras.*



**Force Front Camera:** To force front camera, press and hold radio **'SCREEN OFF'** button for 2 seconds (truck chassis) or **'FRONT DEFROST'** (car chassis). To exit Front Cam mode, press and release the **'BACK'** button.

- If using AUX video mode for an A/V source, the red & black RCAs located on the *Plug & Play T-Harness* must be opened up with an AVSW (KIT763 includes AVSW, or it can be ordered separately as NTV-KIT224).



**Activate Aux Video mode:** To activate the AUX screen, press and hold both radio **'SCREEN OFF'** & **'BACK'** buttons together for 2 seconds (truck chassis) or **'REAR DEFROST'** (car chassis). To exit forced front camera, press and release radio **'BACK'** button.



**Activate CIM (Control in Motion):** To activate CIM for factory navigation, press and hold the 'Volume' button for 3 seconds (CIM will disable automatically after 3 minutes). This function will also keep the Cargo Camera enabled for 3 minutes, and will reset upon every key cycle.

**NOTE:** *Activating the CIM function will NOT bypass video in motion at this time, if equipped.*



**Q1. I can't get into programming mode.**

A1. Turn off the vehicle and remove the key. Close all points of entry and use the remote to lock the vehicle. Wait approx. 5 minutes without opening or disturbing the vehicle. Unlock and cycle the ignition to the 'RUN' position. ***Make certain that the cluster is in FM radio mode before you begin programming;*** and no errors are displayed (door open, etc), otherwise the cluster information might not display. Hold down the "MUTE" button until you see the display options post on the cluster.

**Q2. When I try to force (front, rear) camera, nothing happens.**

A2. Make certain you've enabled the options you want to use in the NAVTV settings mode and that you scrolled to the end *and selected 'EXIT' (or it will not save).*

**Q3. I hear no audio when my auxiliary source is playing on screen.**

A3. Verify that the audio RCAs are connected properly to the AVSW.

**Q4. Everything works properly, but when an audio source is connected to the 3.5mm audio jack, there's no audio.**

A4. Make sure the audio RCAs are connected together on the Plug & Play harness.

**Q5. When I place the vehicle into reverse, I get a black or blue screen.**

A5. Make sure the camera is getting sufficient power and the RCA is connected to the proper yellow RCA on the 24-pin harness.

**Q6. The camera image is displayed properly when the vehicle is in reverse, but there's only a black or blue screen when the camera is forced.**

A6. Make sure the camera power is not connected to the reverse lamps. Camera power needs to be connected to an accessory wire (cigarette lighter). If the camera is OEM, forcing it to display in any gear is *not* supported.