

NAV-TV

INTERFACING THE FUTURE

3950 NW 120th Ave, Coral Springs, FL 33065 TEL 561-955-9770 FAX 561-955-9760

www.nav-tv.com info@nav-tv.com

BHM
02/14/17
NTV-DOC285

IOB-RVC

NTV-KIT798



Overview

The IOB-RVC interfaces a *single backup camera input* to the factory media screen in select GM vehicles equipped with 7" MYLINK (IOB) media systems. With additional parts, HDMI input or Navigation is available with this unit (available soon). *Audio integration requires the use of the OEM AUX input if adding an A/V source.*

Kit Content

HD-LINK Optional KIT800



Optional VSW-R (front camera)



IOB-RVC Interface



Power/CAN T-Harness



LVDS Input cable



LVDS Output cable



IR Eye Harness



OSD Menu Remote

Agreement: End user agrees to use this product in compliance with all State and Federal laws. NAV-TV Corp. would not be held liable for misuse of its product. If you do not agree, please discontinue use immediately and return product to place of purchase. This product is intended for off-road use and passenger entertainment only.

Interface Connectors

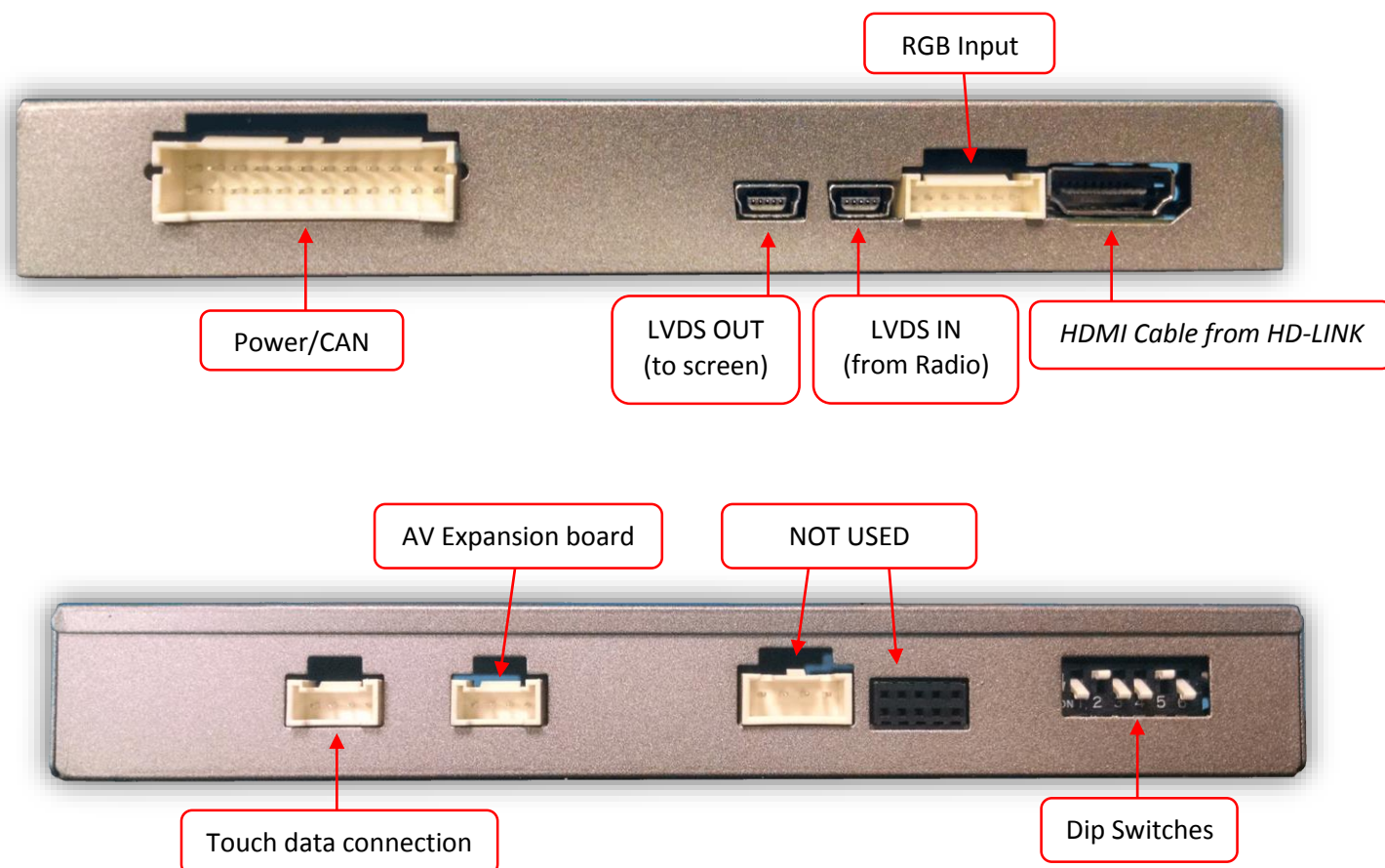

Dip Switch Settings* Configure prior to installation

Dip SW:	1	2	3	4	5	6
UP	DIGI-RGB OFF	N/A	NO NAV	OEM camera	N/A	Leave DOWN
DOWN	DIGI-RGB ON	N/A	ADDING NAV	Adding rear cam	N/A	Leave DOWN



***Note: You must remove power to the unit prior to making adjustments to the dip switches. When power is reconnected after the dip switch adjustment the new settings will be stored into memory.**

Screen Removal and Interface Installation (Silverado)

NOTE: After completing installation, you MUST perform a CAN reset to the vehicle: Close all doors and lock, return in 10 minutes before testing unit.

1. Remove the trim surrounding the main media screen using plastic tools and set it aside.
2. Remove (4x) 7mm screws securing the screen assembly to the sub-dash. Disconnect all connectors and set the screen aside.
3. Locate the (gray & brown) OEM plugs connected to the radio indicated here (right), and connect the provided **T-Harness** portions of the **Power/CAN Harness** in between the car side and the radio.
4. Connect the **OEM LVDS Video Cable** previously removed from the **screen** (not the radio) to the port on the IOB-RVC interface labeled 'VIDEO IN' (use provided extension if necessary).



5. Connect the provided **LVDS Output Cable** from the 'VIDEO OUT' connector on the module, directly to the screen LVDS Video port. Make certain the connector is seated firmly.

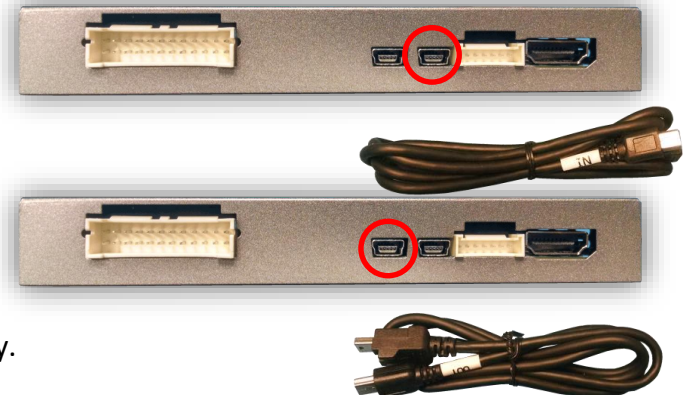

6. Connect the 12-pin white connector to the module at the port labeled 'POWER CAN'.
7. Connect your camera signal RCA to the yellow female RCA among the main power harness labeled 'CAMERA'. **NOTE: if this vehicle has an OEM camera, you must connect the male RCA among the**
8. The **purple wire** on the main power harness **outputs 12v (+) when in reverse only** (500mA max) and may be used for (single) camera power.
9. The **green wire** on the main power harness is used to **force the rear cam or AV1 video input RCA** (selectable – through OSD menu. See page 5 for menu options)
10. The clear **4-pin molex** connector (from main power harness) is not used.
11. **Optional:** If adding multiple camera/video sources, see **FIG 2** on page 8.
12. Proceed to **IOB-RVC Operation** on page 4.

IOB-RVC Operation

- After all connections are made and **dip switches set properly**, start the vehicle. Placing the vehicle in reverse will show the connected rear camera, with dynamic guidelines overlaid onto the media screen.
- If adding a front camera (**requires VSW-R**), this must be activated in the OSD menu (see page 5). Forcing this camera on at any time is performed by double-tapping the **HOME** button on the screen bezel twice. **The module will cycle through video modes in this order: OEM>NAV/HDMI>OEM.**
- If the user wishes for the front camera to be set on a **timer** (front camera shows after leaving reverse gear, for preset amount of time), activate this feature in the OSD menu (see page 5).
- Holding the **HOME** button for ~5 seconds **while in reverse** will cycle through the available PIP (picture in picture) options.



Setting/Navigating OSD Menu

Before you start:

- The IR-Eye must be connected
- Make sure the car's ignition is on and radio is on
- You must be in **Reverse Camera** mode **OR AUX Video** mode (see below):
 - **Reverse Camera Mode** adjusts Reverse Camera Settings
 - **AUX Video Mode** adjusts AUX Video Settings
- Press the **OK BUTTON 4 times** (numbers will display per press), then press **POWER**.
- The **OSD Menu** will appear on screen (auto-time out in about 5 seconds if no action occurs).



Return
(AUX VID menu control)

RVC Menu

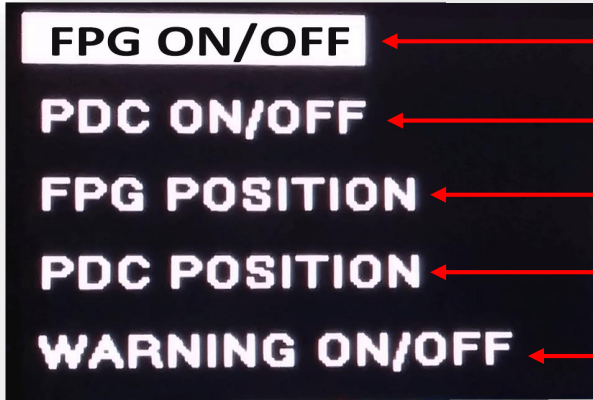

Functional Parking Guidelines ON/OFF

Parking Distance Control ON/OFF (while in reverse)

Adjust FPG Position

Adjust PDC Position

'Safe to move?' ON/OFF

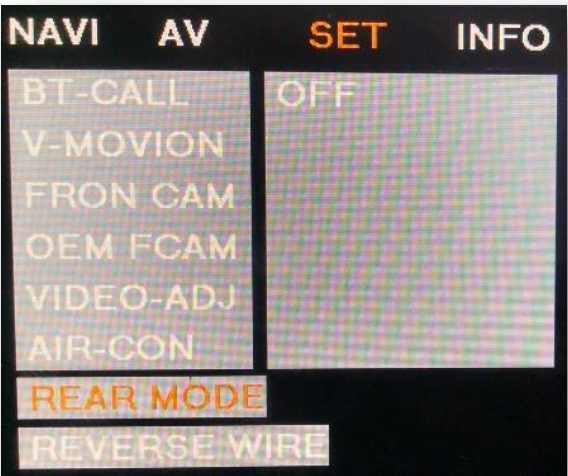
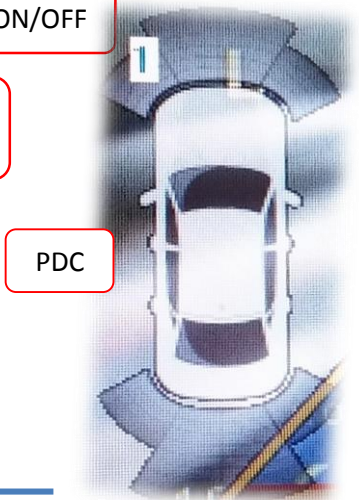

If adding a front camera OR Aux Video source (requires VSW-R):

1. Disconnect POWER/CAN Harness from interface
2. Place DIP SWITCH 1 in the DOWN position, reconnect power
3. Double-tap the **HOME** button on the dash to activate 'NAV INPUT'
4. Press **OK** button on remote 4 times, then press **POWER**
5. Navigate to '**SET**', and set '**REVERSE WIRE**' to '**REAR**'
6. Let OSD menu time-out (5 seconds)
7. Follow the diagram on page 8 (FIG 2) and make connections.

Once finished with settings, place DIP SWITCH 1 back into the **UP position** and reset power to interface.

Agreement: End user agrees to use this product in compliance with all State and Federal laws. NAV-TV Corp. would not be held liable for misuse of its product. If you do not agree, please discontinue use immediately and return product to place of purchase. This product is intended for off-road use and passenger entertainment only.

OSD Menu Options (continued)

BT-CALL

- **BT-CALL:** How a (OEM setup) Bluetooth phone call is handled while in AV/HDMI mode:
 - **ON** - When in AV/NAV mode, the unit will transition to the OEM screen when a Bluetooth phone call is active, then return when call is ended.
 - **OFF** - There is no screen transition when a BT call is active. The screen will remain in whatever mode it is currently on.

FRON CAM

- **V-MOVION:** N/A
- **FRON CAM:** Front camera timer (AV1) = without expansion board; (AV3) with expansion board
 - **5s, 7s, 9s, 11s:** Choose one (timer, in seconds), for the amount of time the *front camera (AV1)* shows after the vehicle is transitioned out of reverse gear
 - **OFF:** No timer activation

VIDEO-ADJ

- **OEM FCAM:** N/A
- **VIDEO ADJ:** Adjust video settings for AV1/HDMI/NAV, etc
- **AIR-CON:** Used on vehicles that display the HVAC/volume information on the screen whenever an adjustment is made.
 - **ON:** When in AV/HDMI mode, the screen will transition to the OEM screen to display the HVAC/volume adjustment, then auto transition back to AV mode.
 - **OFF:** When in AV/HDMI mode, the screen will remain while HVAC/volume adjustments are made.

AIR PIP ON

- **NOTE:** another method for enabling/disabling this (labeled as 'AIR PIP') is by **pressing and holding the 'BACK' button (dash control) for 7 seconds.**

- **REAR MODE:** Used to determine operation when the vehicle is placed into reverse.

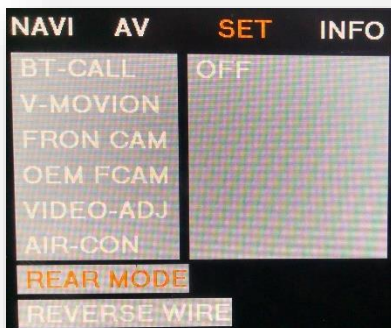

- **ON:** RVC dip switch (#4) dependent (follows DS #4).
 - **OFF:** The unit will ignore the reverse gear/wire. (No screen transition in AV or OEM)
 - **DIP 4 ON: Aftermarket camera input:** In AV/HDMI or OEM, the screen will transition to the RVC input when reverse is detected. Will display any extra overlay info, PDC, active guidelines.
 - **DIP 4 OFF: OEM equipped camera:** In AV/HDMI the unit will transition into the OEM screen when reverse is detected.
- **REVERSE WIRE:** Providing 12v (+) to the **green wire** acts as an external activation for the selected input (connect through toggle switch, SVS-6, etc).
 - **REAR MODE:** Follows the REAR MODE operation (with guideline overlay and any additional options)
 - **REAR:** Displays the RVC input video in its raw form (no extra overlays)
 - **AV1:** Displays AV1 input

Adding HD-LINK Adapter (HDMI Input)

Follow the instructions below when adding the HDMI adapter (HD-LINK) to enable HDMI input to the OEM screen:



1. Put dip switch #1 in the **DOWN** position.
2. Activate the 'NAV INPUT' by double-tapping the 'HOME' button on the dashboard.
3. Once 'NAV INPUT' shows on the screen, on the remote press the **OK BUTTON 4 times**, then press **POWER**.
4. Navigate to the 'NAVI' section.
 - a. Select 'HDMI-SEL'
 - b. Choose 'HD95E'
 - c. Press **MODE** on the remote to return and exit the OSD menu (or let it time out).
5. Replace dip switch #1 to the **UP** position.
6. Connect the **black wire** to ground (-) and the **red wire** to ACC power (+) from the main power connector on the **HD-LINK** adapter. The RCA's on this plug provide audio from the HDMI source.

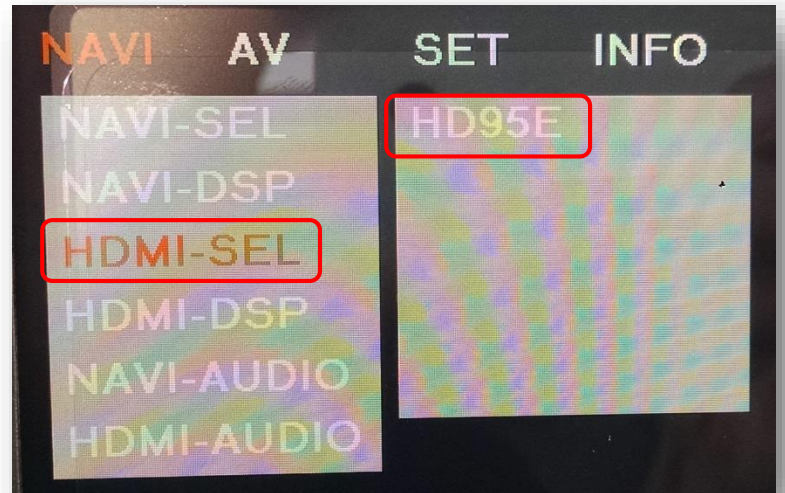
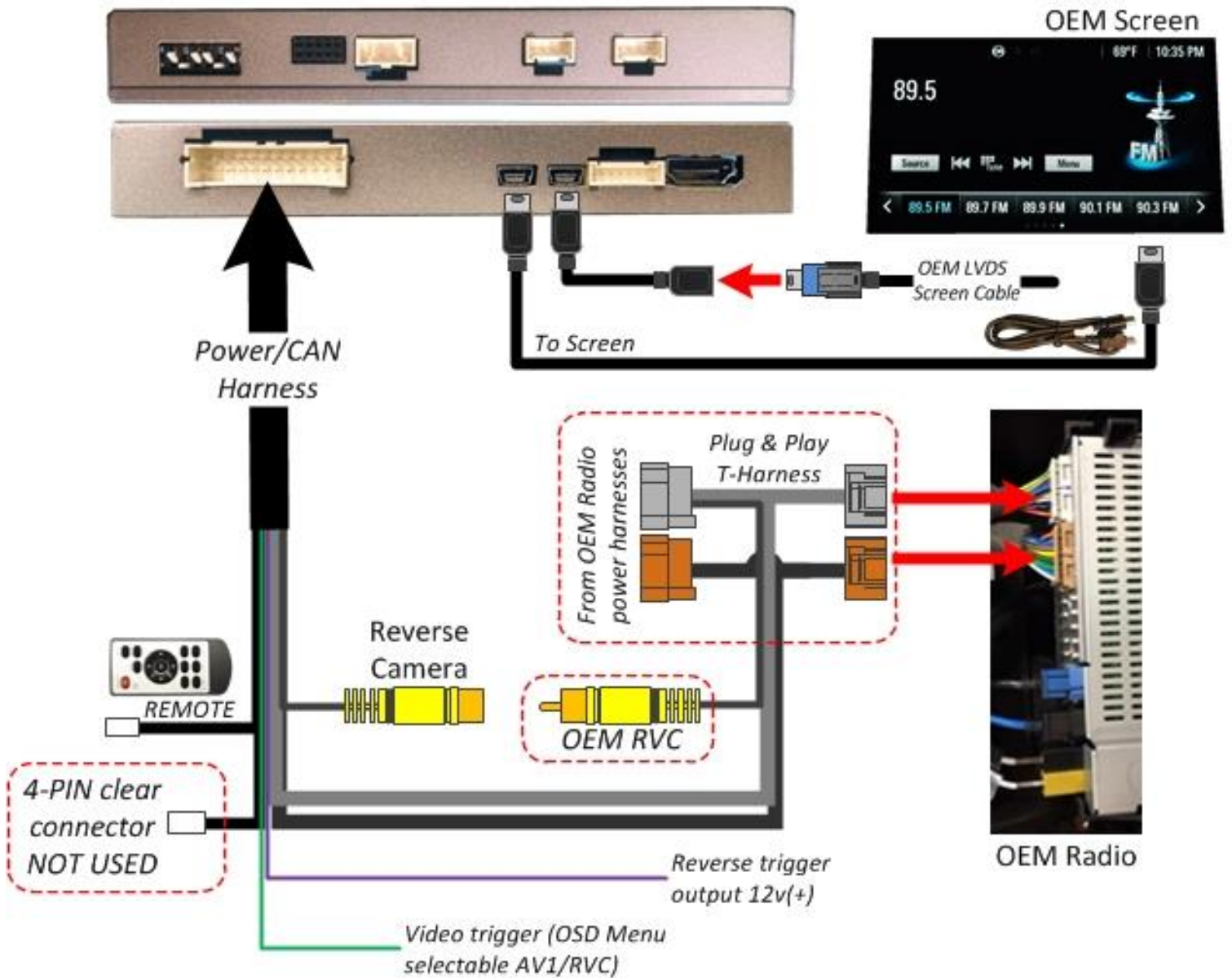
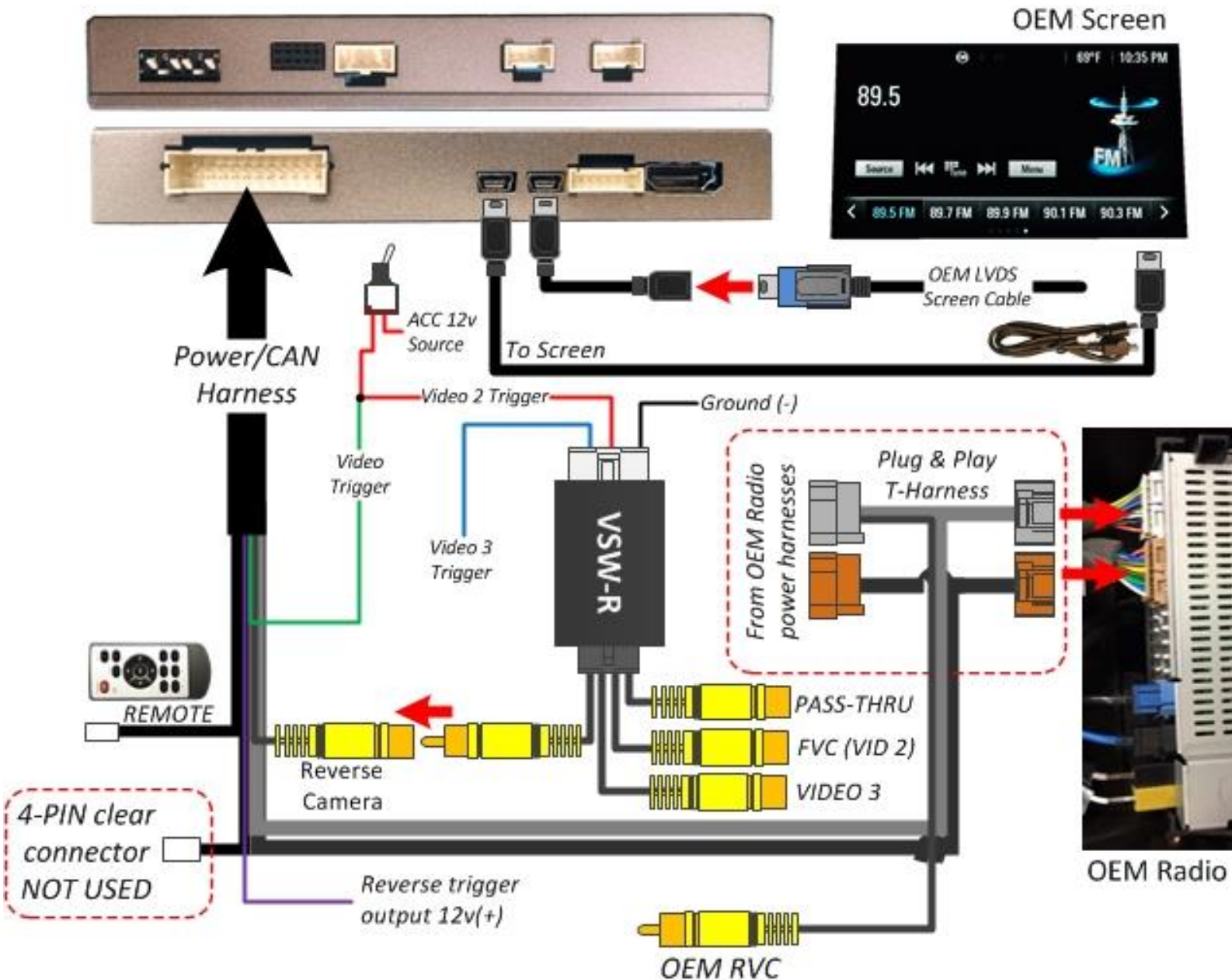

FIG 1: IOB-RVC Connection Diagram (adding single aftermarket RVC)



Agreement: End user agrees to use this product in compliance with all State and Federal laws. NAV-TV Corp. would not be held liable for misuse of its product. If you do not agree, please discontinue use immediately and return product to place of purchase. This product is intended for off-road use and passenger entertainment only.

FIG 2: IOB-RVC Connection Diagram (adding FVC or AUX Video)



NOTES for adding front camera/AUX Video:

- 'REVERSING LINE' (green wire) in AUX OSD menu must be set to 'REAR'
- Toggle switch is not included
- ACC 12v (+) source and Ground (-) source may be spliced from 4-pin clear connector (normally not used)
- If static or ghosting appears when adding FVC/AUX video *in conjunction with OEM rear camera*, NAV-TV D2C kit must be added. *In this situation, 'OEM RVC' connects to 'VIDEO 1' RCA on the VSW-R.*

Agreement: End user agrees to use this product in compliance with all State and Federal laws. NAV-TV Corp. would not be held liable for misuse of its product. If you do not agree, please discontinue use immediately and return product to place of purchase. This product is intended for off-road use and passenger entertainment only.

IOB-RVC FAQ

1. ***I've installed this interface properly, now I have a black screen in park and reverse.***
 - a. Make certain the IN and OUT LVDS video cables are connected in the proper location (at the screen and proper direction), and seated fully. The 'OUT' cable should go directly to the screen, and the 'IN' cable is really just an extension, and should be connected from the OEM LVDS cable previously connected to the screen.
 - b. This kit connects at the screen for video interception.
 - c. Make sure the provided 'OUT' connector at the screen is seated fully into the screen (may need to wiggle it in or even shave some rubber from the plastic).
 - d. Verify the LEDs on the inside of the unit are twinkling with the key on. If not, check the fuse on the **red** power line going into the main connector of the unit.
2. ***Nothing happens when I place the vehicle in reverse – it stays on the OEM screen.***
 - a. Be certain DIP SWITCH #4 is ON (down). This enables the RVC port on the module.
3. ***The connectors are not the same for the plug & play portion of the T-Harness, behind the screen.***
 - a. Verify you have an 'IOB' RPO code located on the OEM RPO sticker (glove box or spare tire well). If this vehicle has an 8" IO5 or IO6 radio, this unit is not compatible.