

# NAV-TV

INTERFACING THE FUTURE

3950 NW 120<sup>th</sup> Ave, Coral Springs, FL 33065 TEL 561-955-9770 FAX 561-955-9760

## GM UNI-CAM/UNI-CAM PRG

*RVC controller interface &/or programmer for select GM vehicles equipped with MyLink IOH Radio  
IOH = IO4 (4" screen) & IO5/IO6 (8" screen)*

*NTV-KIT629: Controller ONLY (for vehicles with OEM RVC)*

*NTV-KIT630: Controller & Programmer (for vehicles without OEM RVC)*



BHM  
05/09/17  
NTV-DOC239

## Overview

The GM UNI-CAM adds an additional video input on select GM vehicles equipped with the MyLink (model IOH) 4" and 8" color media screens. Forcing (aftermarket) AUX Video or front camera to display at any time is activated with wire triggers. *Note: NTV-KIT629 is a controller only, it will NOT program the MyLink radio system for rear camera. If adding a reverse camera to a vehicle without OEM RVC and forced cam/AUX video input is desired as well, you must purchase NTV-KIT630 (UNI-CAM with built-in programmer).*

## Kit Content



GM UNI-CAM Module  
KIT629: NTV-ASY166  
KIT630: NTV-ASY245



USB Cable  
(updates)  
NTV-CAB009

## GM UNI-CAM Pinout

Pin #	Description	Color
1	12v Constant Power (+)	Yellow
2	Input 1 (Force Rear Cam)*	Red
3	Input 2 (Force Front Cam)	Blue
4	Input 3 (4" Programming Wire)**	Pink
5	--NOT USED--	Brown
6	RCA Signal (+) (Out to radio)	Yellow
7	RCA Shield (common)	Gray
8	CAN HI (HMI side)	White/Blue
9	CAN LO (vehicle side)	White/Brown
10	Ground (-)	Black
11	Output 1 (ACC 12v +)	White/Red
12	Output 2 (REV 12v + & FRVC)	White/Blue
13	Output 3 (12v + out when FFVC)	White/Purple
14	--Not Used--	White/Brown
15	RCA Signal (+) Input (front cam)	White
16	RCA Signal (+) Input (rear cam)	Red
17	CAN HI (HMI side)	Blue
18	CAN LO (vehicle side)	Brown

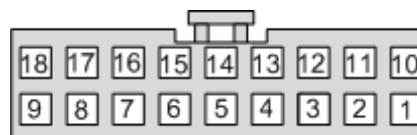

Wire Side

Any wires not mentioned here are not used for this installation.

\*Forcing rear camera is only available for **aftermarket** cameras (unless OEM rear camera is powered with an ACC source or OUTPUT 2 manually – OEM RVC normally only powered in reverse)

\*\*Used for (IO4) 4" screens ONLY.

**PIN 12 FRVC:** 'Forced Rear View Camera'  
**PIN 13 FFVC:** 'Forced Front View Camera'

## GM UNI-CAM Installation

The UNI-CAM kit connects at the OEM **HMI Module**. The location of this module varies by vehicle.

### Known HMI Locations:

Vehicle	HMI Location
Cadillac ATS/CTS	Directly below glove box
Cadillac SRX	Below/behind glove box
Corvette	Driver's kick panel
Silverado/Sierra	Behind glove box - high
Colorado/Canyon	Behind Screen - low



**Factory GM HMI (Human Machine Interface)**

1. After gaining access to the HMI module, Disconnect the gray, 12-pin plug from the OEM HMI circled above.
2. Disconnect the black, 16-pin plug from the OEM HMI circled above.
3. Connect the provided UNI-CAM 12-pin & 16-pin (male end) connectors into the HMI plug locations from steps 1 & 2.
4. Connect the factory 12-pin & 16-pin plugs (previously connected to the HMI) into the provided Plug & Play T-Harness (female end).
5. **NTV-KIT629 Installation (with existing OEM reverse camera):**
  - a. When connecting a front camera (or AUX video source) to a vehicle with an **existing OEM reverse camera**, the internal relay on the UNI-CAM board is not used (RCA I/Os from module). Complete all connections on page 5 (FIG 2) using the included VSW-R (included with KIT629) to prevent 'bleed-over' image (when in front camera mode). This includes the following:
    - b. **Black wire** of VSW to chassis ground
    - c. **OUTPUT 3** (from module) to White/Red of VSW
    - d. RCA connections as shown in diagram (FIG 2)
    - e. Continue with installation on page 4, step 7.
6. **NTV-KIT630 Installation (without existing OEM reverse camera):**
  - a. **Adding a single rear camera:** power your camera with an ACC source **or** OUTPUT 1 (especially if using the forced feature), and connect your camera signal directly to the female RCA (into the HMI) from the 12-pin gray plug.
  - b. **Adding 2 aftermarket cameras:** Instead of connecting camera signal directly to the HMI, connect the RVC signal to the RCA labeled '**BACKUP CAM**'. Connect the front cam/AUX video to the RCA labeled '**FRONT CAM**'. Connect the (male) '**VIDEO OUT**' RCA to the female RCA from the *CAM T-Harness* (at the HMI). Leave the male RCA on the CAM T-Harness disconnected.
  - c. **If this vehicle is equipped with a 4" screen, connect INPUT 3 (pink) to a CONSTANT 12 source.**

**NOTE: If this wire is not connected, the UNI-CAM PRG will program for 8" screen (image will appear zoomed in).**

- d. Continue with installation on step 7 (next page).



7. **Optional:** Connect *INPUT 1* &/or *INPUT 2* to an ACC 12v (+) source **through toggles** for displaying rear view camera and front view camera (or AUX video) at any time.  
**NOTE:** the factory GM screen may generate parking guidelines (while in reverse), which can be turned off in the OEM settings (through radio). This is usually required when using the UNI-CAM for an additional AUX video input.
8. Connect the UNI-CAM module to the 18-pin plug located on the Plug & Play T-Harness.
9. **KIT630 ONLY:** Proceed to **UNI-CAM Programming**. **Note:** *If vehicle already possesses a rear camera, this programming step is not needed!*

10. **Optional (pickup trucks):** If the user wishes to force the OEM Reverse camera at any time, you must power the OEM camera power wire manually. Complete the connection shown in the diagram below.

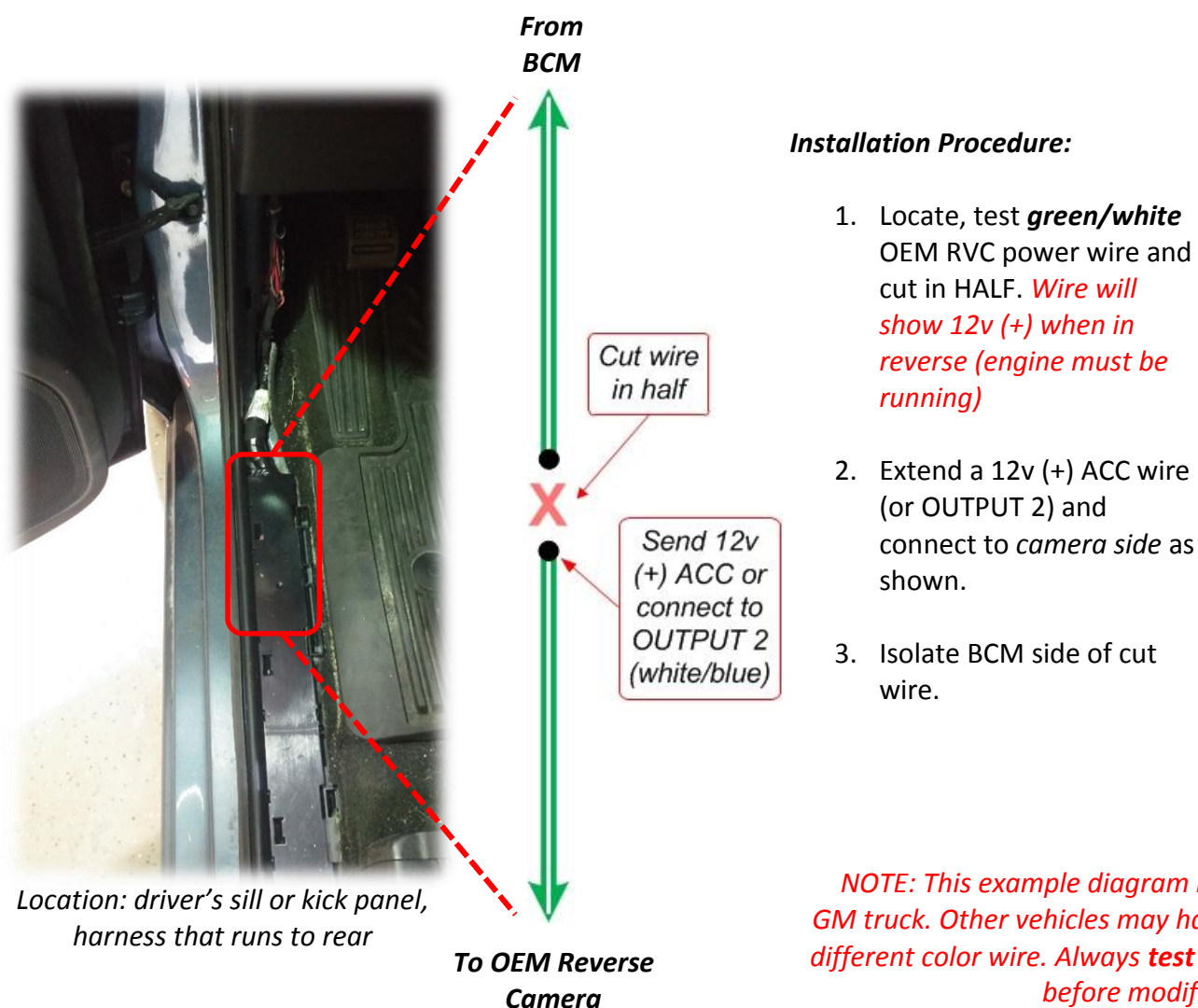

11. **Optional (SUVs):** If the user wishes to force the *OEM Reverse camera* at any time, you must power the OEM camera power wire manually. Complete the connection shown in the diagram below.

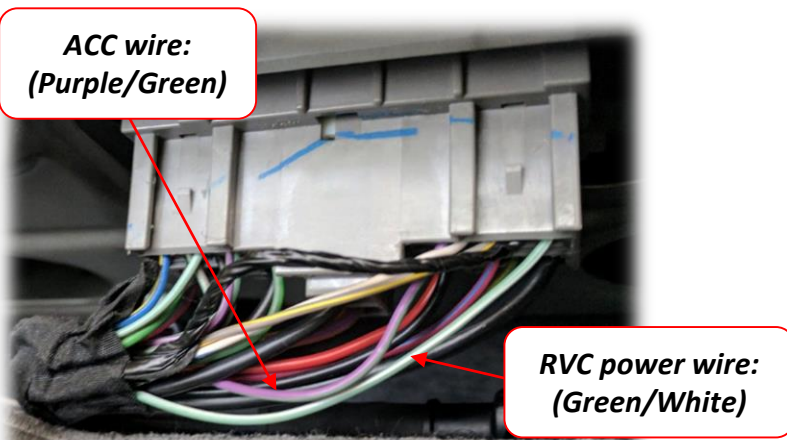

*Location: Back of truck, lift gate open, top center connector from vehicle to lift gate (in headliner)*

**Modification Procedure:**

1. Locate, test **green/white** OEM RVC power wire at the tail-gate harness connector and cut in HALF. *Wire will show 12v (+) when in reverse (engine must be running)*
2. Connect the **camera side (lift gate side)** of the cut wire to the **purple/green** ACC wire.
3. Isolate BCM side (front of vehicle side) of cut wire.

*NOTE: This example diagram is for GM SUV. Other vehicles may have a different color wire. Always **test wires** before modifying.*

GM UNI-CAM Diagram (adding aftermarket cameras)

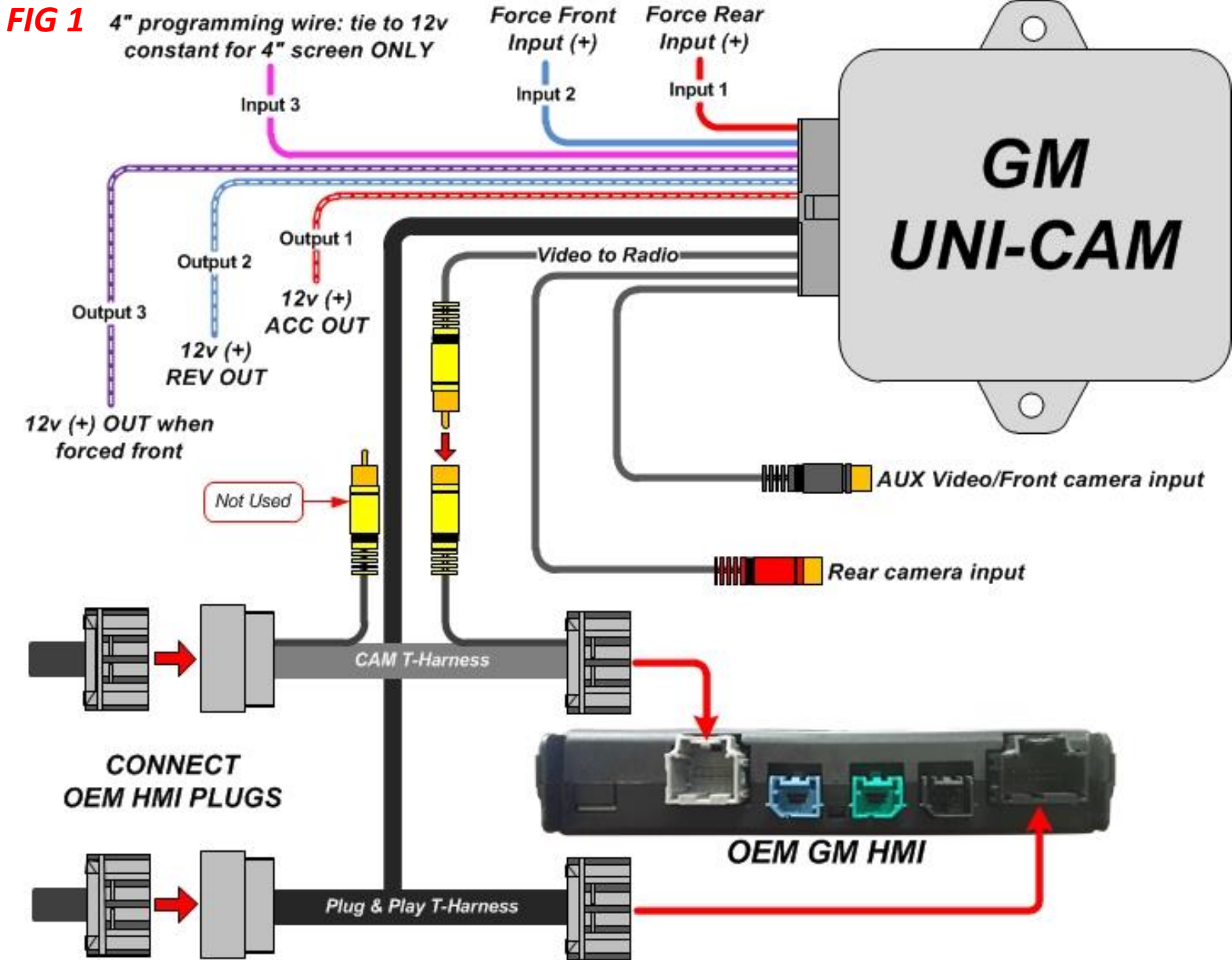

Agreement: End user agrees to use this product in compliance with all State and Federal laws. NAV-TV Corp. would not be held liable for misuse of its product. If you do not agree, please discontinue use immediately and return product to place of purchase. This product is intended for off-road use and passenger entertainment only.

GM UNI-CAM Installation (*adding AUX video with existing OEM RVC*)

**FIG 2**

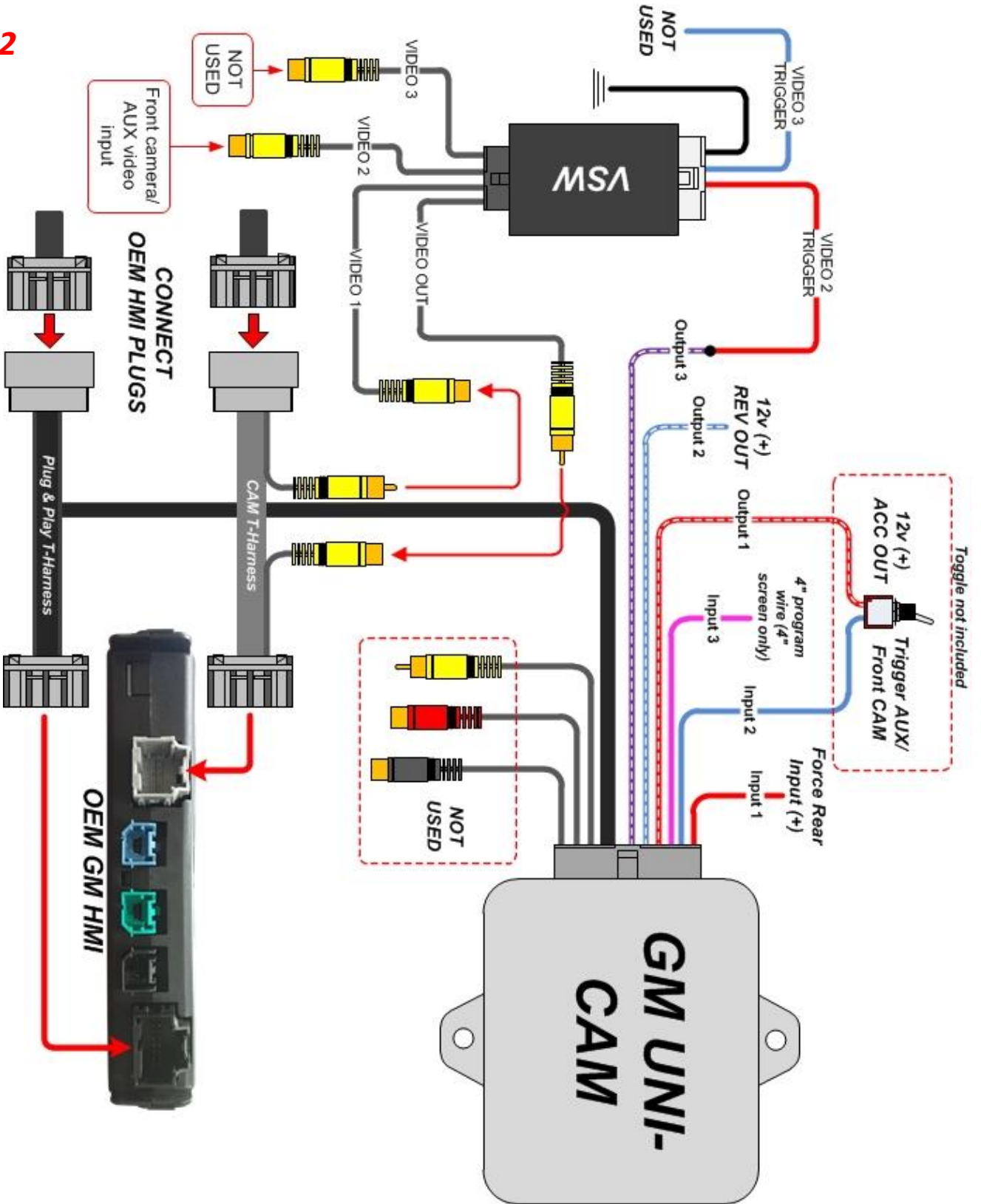

Agreement: End user agrees to use this product in compliance with all State and Federal laws. NAV-TV Corp. would not be held liable for misuse of its product. If you do not agree, please discontinue use immediately and return product to place of purchase. This product is intended for off-road use and passenger entertainment only.



**GM UNI-CAM Programming (KIT630 ONLY)**

**DISCLAIMER: Do NOT disconnect the programmer during programming – this may result in complete radio brick (factory limitation). NAV-TV is not responsible for failure to comply with this rule.**

1. Once all connections are made, turn the key to the **IGNITION ON** position. Watch the LED on the UNI-CAM Module and verify flash codes below.
2. Wait for radio to **reboot fully. The radio may reboot more than once – wait a little while.**

*Programming is complete when the LED flashes 5 times.*

LED Response	Description
1 flash	<b>Waiting for Ignition...</b> (Turn ignition to ON)
2 flashes	<b>Waiting for Vehicle VIN...</b>
3 flashes	<b>Query Vehicle</b> (Reading/decoding the VIN and vehicle components)
4 flashes	<b>Programming...</b>
5 flashes	<b>Programming Complete</b>
6 flashes	<b>No Programming Needed</b> (Already programmed)
7 flashes	<b>Radio Not Supported</b> (Verify this vehicle is equipped with <b>IOH Radio Code</b> )
8 flashes	<b>Out of Licenses</b> (Contact NAV-TV to purchase more licenses)

3. Cycle the vehicle key once (turn off, wait 5 seconds, turn back to **IGNITION ON**)
4. Verify **6 FLASHES** from LED on module.
5. Verify that the radio accepted the program properly by placing the vehicle in reverse. The reverse screen should appear (or black screen if no camera connected yet) when in reverse only.  
*NOTE: the vehicle may have to be running (engine) for the reverse camera to show (factory limitation)*
6. **UPDATE: if nothing happens in reverse after programming, disconnect the 20-pin power plug (black) at the OEM HMI module, then reconnect to reset the system manually. Once the radio has reset and booted fully, test for rear camera activation again.**



**IMPORTANT NOTE: There is NO De-Programming option with the GM UNI-CAM. Once programmed, this system modification will remain forever.**



