

NAV-TV

INTERFACING THE FUTURE

3950 NW 120th Ave, Coral Springs, FL 33065 TEL 561-955-9770 FAX 561-955-9760

M650-GM

GM IO4/IO5/IO6 M.O.S.T. 50 to RCA, SPDIF & TosLink sound processor

NTV-KIT838



MOST[®]



BHM
10/16/17
NTV-DOC303
rB3

WARNING: Do not connect any RCA cables to the M650-GM interface or additional processors prior to properly grounding aftermarket amplifier(s)!

Overview

NAV-TV's M650-GM processor seamlessly converts GM's MOST-50 audio bus to low level (6 channel) RCA, S/PDIF or TosLink outputs. Adding an aftermarket amplifier to the OE IO5/IO6 system has never been so easy or seamless. This plug & play kit integrates with various OEM data networks to retain OnStar, door chimes, volume control, full fade and balance (analog only), treble, mid-range, bass control & Bluetooth voice calls with no external speaker (true OEM integration). *NOTE: the OEM amplifier must stay connected in the vehicle to maintain complete OE functionality at this time.*

Kit Content



M650-GM overview

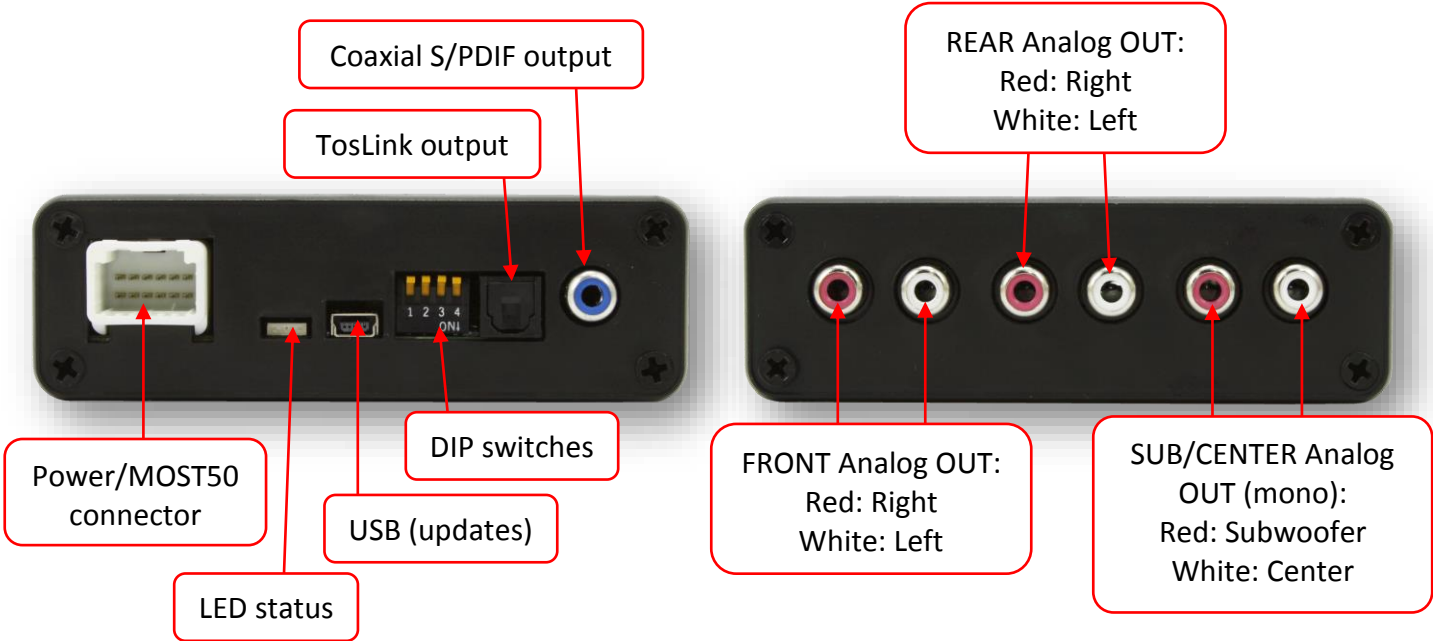

M650-GM Installation

Proper connection for the M650-GM requires gaining access to the OEM **radio tuner module**. Known locations are listed on the chart below:

Vehicle	Radio Tuner Location
Cadillac ATS/CTS/XT5/XTS/SRX	Passenger kick (high)
Cadillac CT6	Trunk, passenger side (vertically)
Cadillac ELR	Trunk, passenger side (floor)
Chevy Impala/Camaro	Passenger kick (high)
Chevy Corvette	Passenger footwell
ALL Trucks/SUVs	Behind Screen

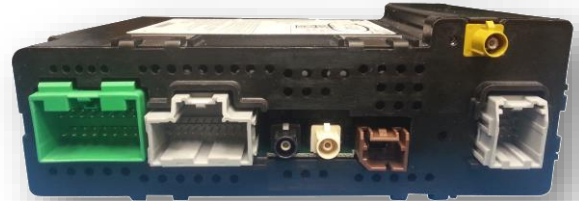

IO5/IO6 OEM GM radio tuner

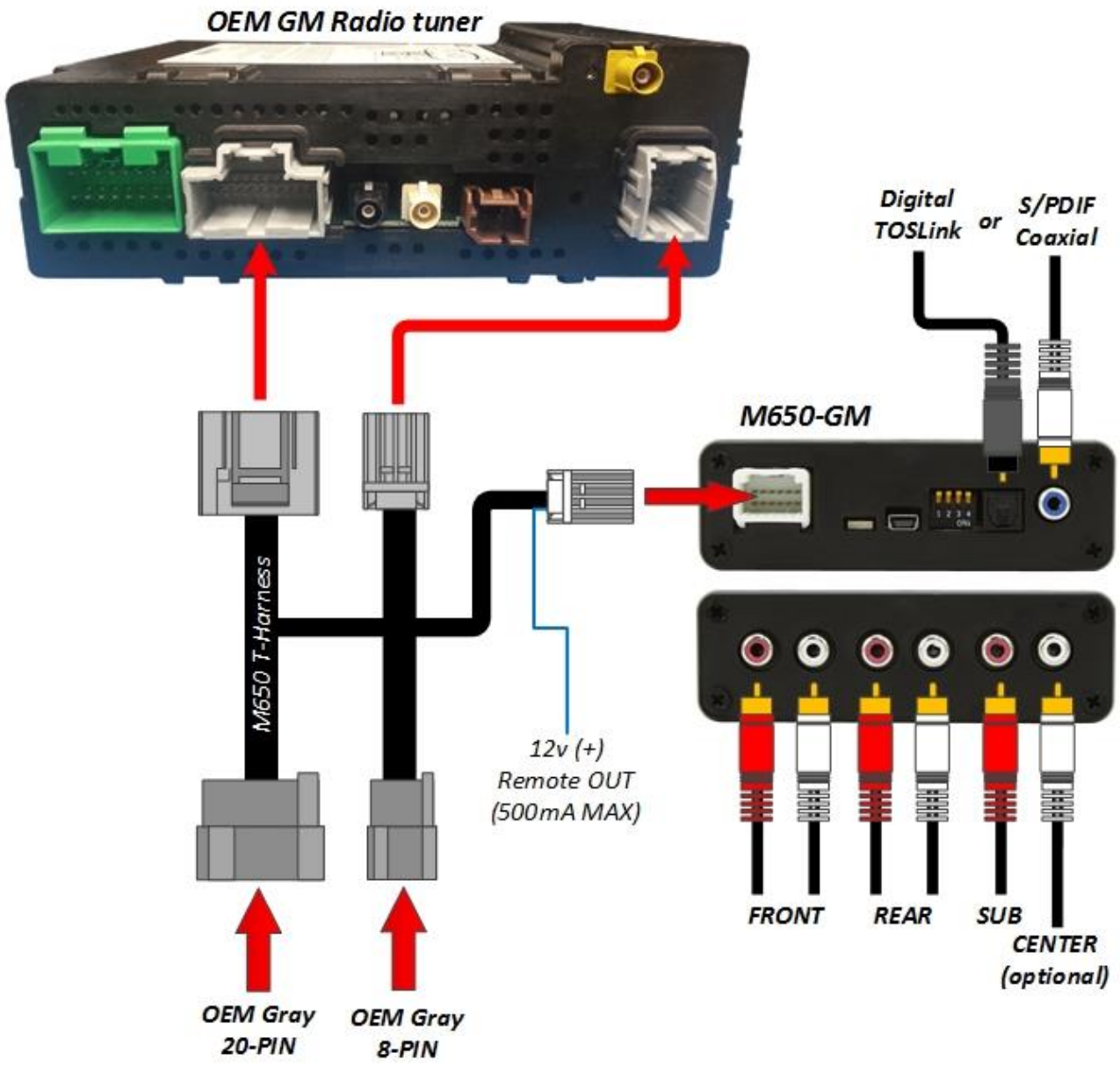

M650-GM Installation

1. Use the chart on page 3 to locate the OEM radio tuner. Remove all panels/dash pieces to access the plugs on the OEM radio tuner.
2. Using the provided **T-Harness**, connect between the proper connectors (gray 20-pin & gray 8-pin) at the OEM radio tuner and OEM harness' from the vehicle.



3. **Before connecting power to the M650-GM**, adjust dip-switch settings for the desired options:



Position	DIP 1	DIP 2	DIP 3	DIP 4*
UP	NO time alignment	Full Scale output (0 dB)	OEM BASS adjustment controls overall BASS frequencies	Loudness OFF
DOWN	Driver time alignment (trucks only)	-12 dB output	OEM BASS adjustment controls SUB output directly	Loudness ON

**NOTE: After installation, if equipped, OEM 'BOSE Autopilot' mode is only retained with DS 4 in the UP (OFF) position. With DS 4 set to ON, Loudness will be controlled by the M650 only.*

4. If using analog RCAs to connect to the amplifier, connect FRONT, REAR, SUB/Center to RCA connectors as shown on page 2. **WARNING: Do not connect RCA cables to this interface until all amplifiers/external processors are properly grounded. Failure to do this may cause damage to the interface and VOID the warranty!**
5. If using S/PDIF for signal to the amplifier, connect to either TosLink or Coaxial connector shown on page 2. **NOTE: both Analog and Digital output sound simultaneously, regardless of which type is used.**
6. Use the provided **blue wire** (extend) for amplifier turn on. **NOTE: this wire must be used for amp turn on, instead of ACC as the amplifier(s) must wake before ignition (for door chimes, etc).** This wire will output 12v (500mA MAX) whenever a door is unlocked (via remote) or opened (data-sensing). Make certain this wire will not short circuit anywhere as it will have power any time the vehicle network is active.

Multi-Color LED Status Indication



LED Status	Indication
Solid Red	MOST Active
Solid Green	GM-LAN Active
Orange	MOST & GM-LAN Active (normal operation)
Violet or White	MOST traffic commands
Blinking Red	Peaking (maximum digital signal level achieved)
Blinking Blue	PC Link with app (future use)
Blinking Green	USB update

M650-GM System Layout Options

TYPE 1: Signal directly to amp, no additional external processor

Any Aftermarket Amplifier

M650-GM

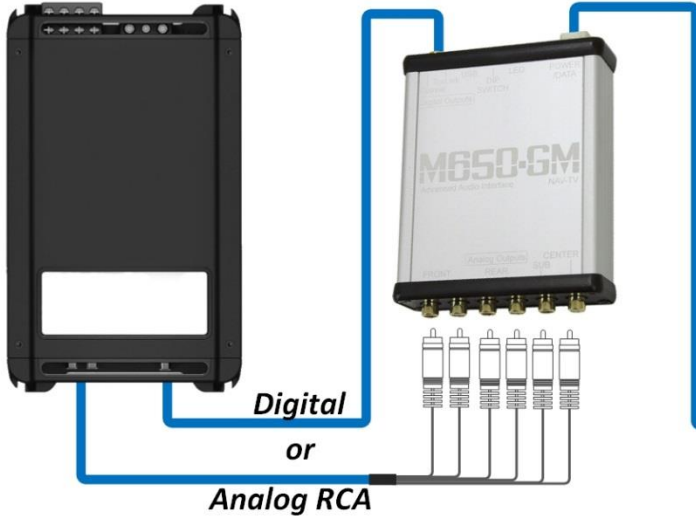

OEM Monitor and Radio Tuner

NOTE: the OEM amplifier must stay connected in the vehicle to retain complete OE functionality



Plug & Play T-Harness Connects at radio tuner



OEM GM Amplifier

TYPE 2: Signal to additional external processor, then to amplifier

Any Aftermarket Amplifier

M650-GM



OEM Monitor and Radio Tuner

NOTE: the OEM amplifier must stay connected in the vehicle to retain complete OE functionality



Plug & Play T-Harness Connects at radio tuner



OEM GM Amplifier

M650-GM Technical Specifications

<i>Hardware & Software</i>	
Current HW version:	Version 2.0
Current SW version:	Oct-13-2017
Compatible SW (update) OS:	Windows 7 (64 bit), 8, 10
<i>INPUT</i>	
Digital Input (MOST 50)	MOST 50 Plug & Play
<i>OUTPUT</i>	
Digital Outputs:	TOS link (1) and S/PDIF Coaxial (1)
Digital Outputs supported:	24bit/48kHz
Frequency Response (digital):	18Hz – 24kHz
Analog Outputs:	6 channels (RCA)
Output Voltage <i>Peak</i> :	3v (peak to peak, with EQ flat) or 6v (selectable)
Output Voltage <i>RMS</i> :	2.1v
Analog Output Type:	Single-Ended
S/N Ratio (analog):	112dB
Frequency Response (analog):	18Hz – 24kHz
THD+N @ -1dBFS	-93dB
DAC	192kHz 32bit
DSP	128bit/Channel Floating Point
Delay (Time Alignment)	Selectable (driver only, pickup only)
<i>Power Supply</i>	
Current Consumption Stand-by	<1 mA
Current Consumption Operational	350 mA MAX
Operational Voltage	7V – 20V DC
Amp Turn-On Output	Automatic
Amp Turn-On Voltage	V-batt
Amp Turn-On Current Limitation	500mA
<i>Other</i>	
Dimensions:	4"x5"x1 3/8"
Weight:	10 oz
Country of Origin:	USA

M650-GM Pin Out

Pin #	Description	Color
1	MOST RX (-)	White/Purple
2	MOST RX (+)	Purple
3	--Empty--	--
4	GM-LAN	Green
5	MOST Wake Up	Pink
6	Ground (-)	Black
7	MOST TX (+)	Orange
8	MOST TX (-)	White/Orange
9	--Empty--	--
10	--Not Used--	White/Blue
11	Remote OUT	Blue
12	12v Batt (+)	Yellow

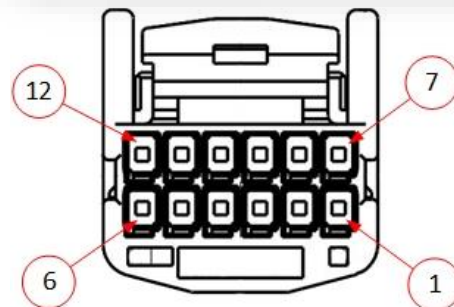

NTV-HAR310
Wire Side

NAV-TV
INTERFACING THE FUTURE

