

NAV-TV

INTERFACING THE FUTURE

3950 NW 120th Ave, Coral Springs, FL 33065 TEL 561-955-9770 FAX 561-955-9760



Mercedes Benz NTG5+ MOST150 to 12-channel Analog & Digital sound processor

NTV-KIT871

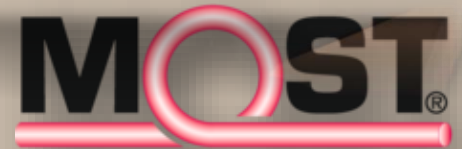

WARNING: Do not connect any RCA cables to the ZEN-M interface or additional processors prior to properly grounding aftermarket amplifier(s)!

Overview

The NAV-TV ZEN-M processor seamlessly converts late model Mercedes factory MOST-150 audio bus to 12-channel analog RCA and TOSLink output. Adding aftermarket amplifiers to the OE NTG5, 5.1, 5.2 or 5.5 system has never been so simple and seamless. This kit integrates with the OEM M.O.S.T.® bus to retain volume control, full fade and balance (analog only), treble, mid-range, bass control & Bluetooth voice calls with no external speaker (true OEM integration). *NOTE: vehicles not equipped with a factory amplified system must be flashed with NAV-TV's ZEN-M-PRG (NTV-KIT866, sold separately) prior to installation. Vehicles equipped with an OEM amplifier do not need to be flashed.*

Kit Content



ZEN MOST Fiber
NTV-CAB134

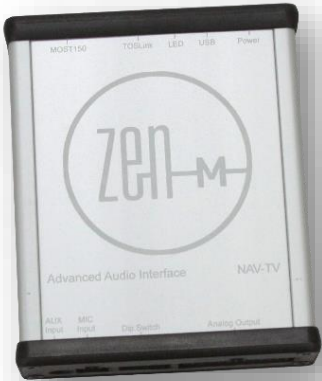

ZEN-M Interface
NTV-ASY272



ZEN Power Harness
NTV-HAR316

ZEN RCA Harness
NTV-HAR315



USB Cable (updates)
NTV-CAB009

ZEN-M overview

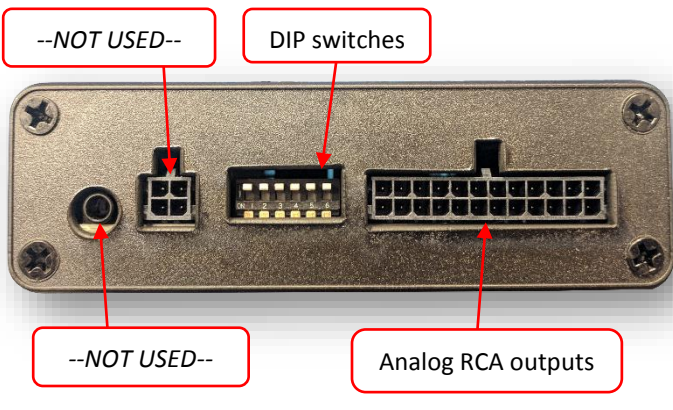
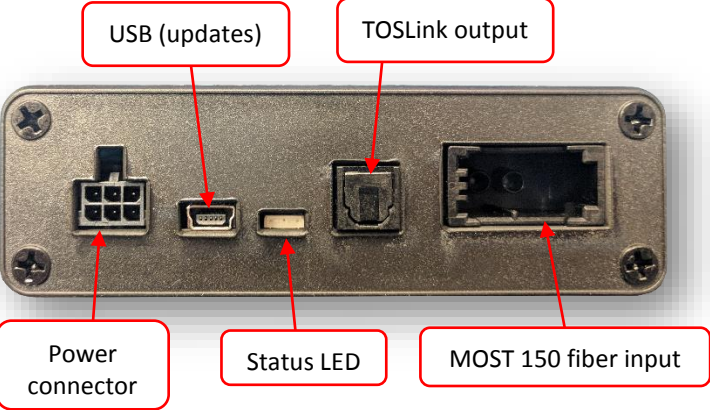

ZEN-M Compatibility (NTG5, NTG5.1, NTG5.2, NTG5.5)

NOTE: All vehicles require NTG5+ radio, regardless if listed on this chart. See radio shots (below) to gain an idea of what to look for.
NTG5, 5.1, 5.2, 5.5

Month, Year(s)	Make	Chassis	Model
09/2015+	Mercedes	W176	A-Class
11/2014+	Mercedes	W246	B-Class
Any 2014+	Mercedes	W205	C-Class Sedan
Any 2015+	Mercedes	C205	C-Class Coupe
03/2015+	Mercedes	X117	CLA-Shooting B
08/2014+	Mercedes	X218	CLS-Shooting B
08/2014+	Mercedes	W218	CLS Coupe
11/2014+	Mercedes	W212	E-Class Sedan
06/2015+	Mercedes	C207	E-Class Coupe
10/2016+	Mercedes	W463	G-Class
09/2016+	Mercedes	X166	GL
09/2015+	Mercedes	X156	GLA
Any 2016+	Mercedes	X253	GLC
Any 2016+	Mercedes	C292	GLE
11/2015+	Mercedes	X166	GLS
Any 2015+	Mercedes	C190	GT AMG
08/2015+	Mercedes	W166	ML
Any 2016+	Mercedes	R172	SLC
Any 2014+	Mercedes	C217, W222, X222	S-Class
Any 2014+	Mercedes	W447	V
Any 2015+	Mercedes	X222	Maybach



ZEN-M Installation

- If this vehicle has a factory amplifier, it must be removed and the ZEN-M can be installed into its place. If this vehicle is not amplified from factory, install the ZEN-M behind the radio.

- Connect the following wires from the provided **power harness**:

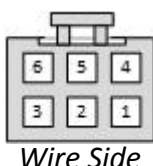

ZEN-M pin	Color	To vehicle:
1	Yellow	12v (+) <i>Constant</i>
3	Violet	--Reserved, NOT USED--
4	Black	Ground (-)
6	Blue	12v (+) remote output*

*This remote wire must be used for aftermarket amplifier remote for proper functionality. **If installing more than one amplifier/DSP, a relay must be used for reliable turn-on (500mA max).**

- Before connecting power to the ZEN-M**, adjust dip-switch settings for the desired options:



	Time Alignment	Attenuation	TOSLink DownMix*	Loudness	Vehicle Settings	
Position	DIP 1	DIP 2	DIP 3	DIP 4*	DIP 5	DIP 6
UP (off)	<i>Front Row</i>	Full Scale output (0 dB)	<i>DownMix ON</i>	Loudness OFF	<i>OFF</i>	<i>OFF</i>
DOWN (on)	<i>Driver Focused</i>	-12 dB output	<i>DownMix OFF</i>	Loudness ON	<i>OFF</i>	<i>OFF</i>

*NOTE: DownMix ON mixes vocals from center channel into Front and Rear L+R output channels.

- If using analog RCAs for signal to the amplifier, connect according to the reference chart below.
WARNING: Do not connect RCA cables to this interface until all amplifiers/external processors are properly grounded. Failure to do this may cause damage to the interface and VOID the warranty!

1	2	3	4	5	6	7	8	9	10	11	12
Left Front	Right Front	Left Front	Right Front	Left Front	Right Front	Left Rear Door	Right Rear Door	Left Rear Center	Right Rear Center	Center	Sub

- If using TOSLink for signal to the amplifier, connect the cable to the TOSLink port shown on page 2.
NOTE: both Analog and Digital output sound simultaneously, regardless of which type is used.
- Connect the provided **MOST Fiber Cable** from the (previously removed) amplifier, or from the radio's fiber port to the MOST port on the ZEN-M. *NOTE: if fiber already exists at the head unit (for SAT radio, etc), you must add the provided MOST fiber cable into the OEM MOST loop (see next page).*

ZEN-M General Installation Notes

- This interface can be installed in vehicles with or without an amplifier & with or without MOST fiber optic presently installed.
 - Vehicles with fiber amplifier: the amplifier must be removed. Connect the OEM fiber previously connected to the amp, directly into the ZEN-M.
 - Vehicles without OEM amplifier or MOST fiber: Use the supplied fiber optic extension and connect from the fiber port behind the radio to the MOST fiber port on the ZEN-M. **NOTE: If the vehicle is not equipped with an OEM amplifier, you must program the system for external amplifier for the ZEN-M to operate properly. Use NAV-TV's ZEN-M-PRG programmer (NTV-KIT866 sold separately).**
 - Vehicles without amplifier but still equipped with fiber*: Disconnect the fiber from the radio, disassemble the fiber coupler and route the provided MOST extension into the factory MOST loop like shown below (to continue proper MOST data flow):

*NOTE: in this scenario, the vehicle still must be programmed for external amp (see red note above).

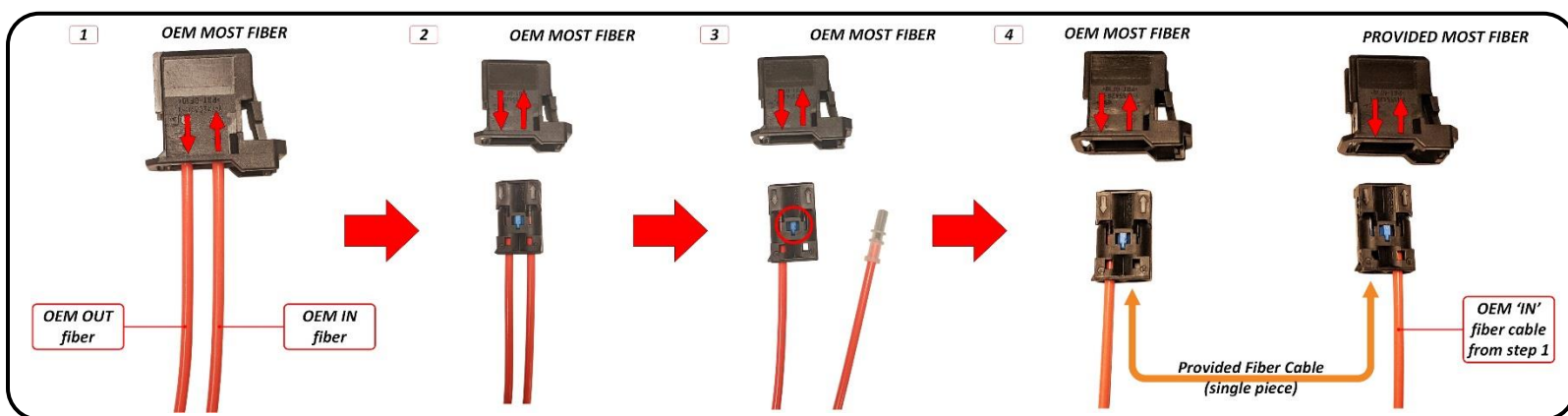

- Tuning tips:**
 - Before beginning tuning process (especially with external EQ/Processors), set Bass & Treble on the head unit for each source to flat (0).
 - Begin with amplifier/EQ gains all the way **down**.
 - With dynamic music playing, adjust the radio volume to maximum.
 - Adjust the amplifier/EQ gains to desired maximum level.
- For Mercedes, there is no separate dedicated subwoofer control.
- NOTE:** The CENTER Channel in some Mercedes vehicles is a DUAL-VOICE coil speaker – one coil is connected to the factory amp the other coil connects to the OEM EMBRACE module – see **page 9** for wiring diagram.

Multi-Color LED Status Indication



LED Status	Indication
<i>Solid Red</i>	MOST Active
<i>Violet</i>	MOST traffic commands
<i>Blinking Red</i>	<i>Peaking</i> (maximum digital signal level achieved)
<i>Blinking Blue</i>	PC Link with app (future use)

ZEN-M System Layout (analog)

For ZEN-M installations, the factory amplifier MUST be removed (if equipped).

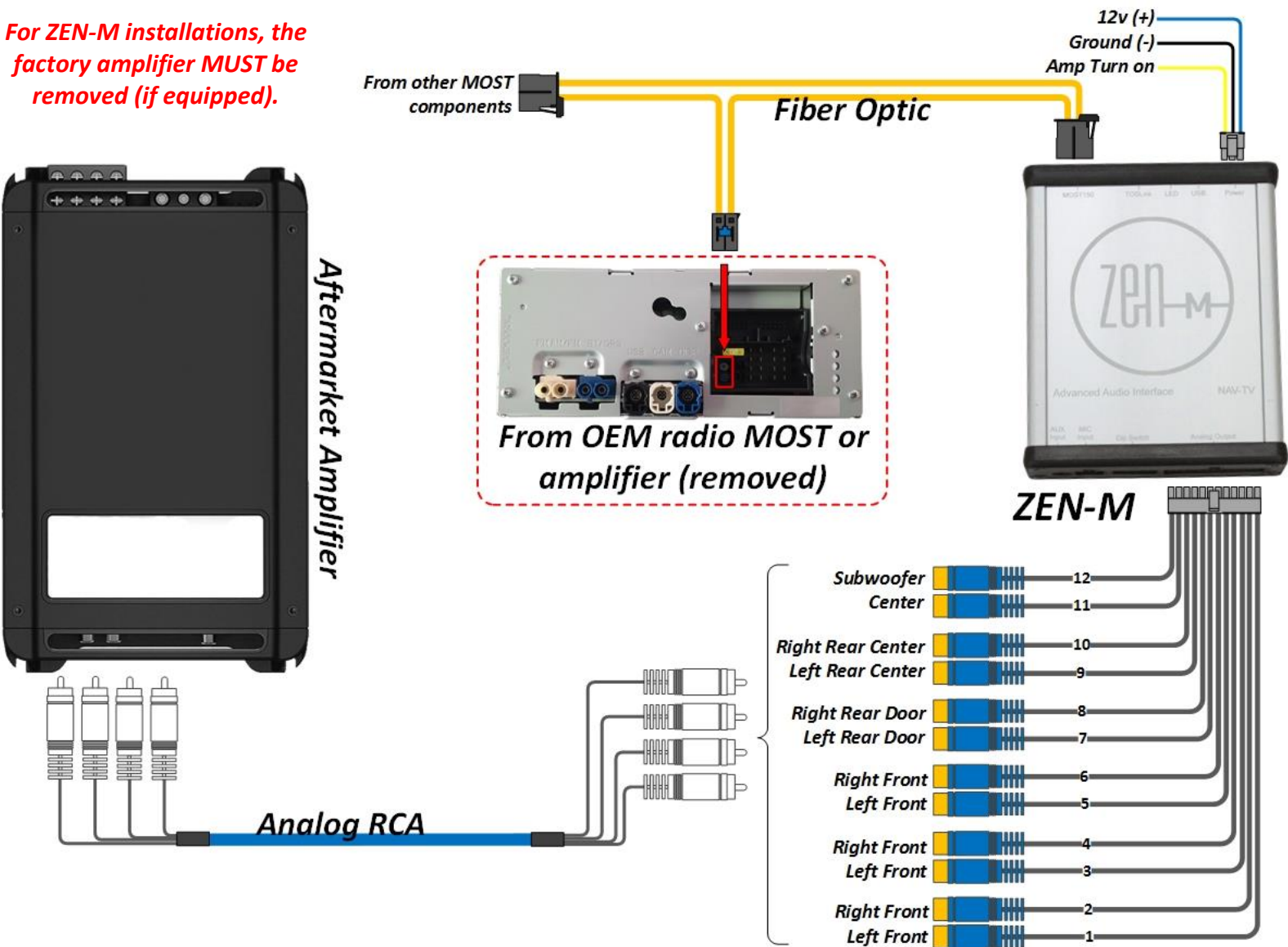

ZEN-M System Layout (digital TOSLink)

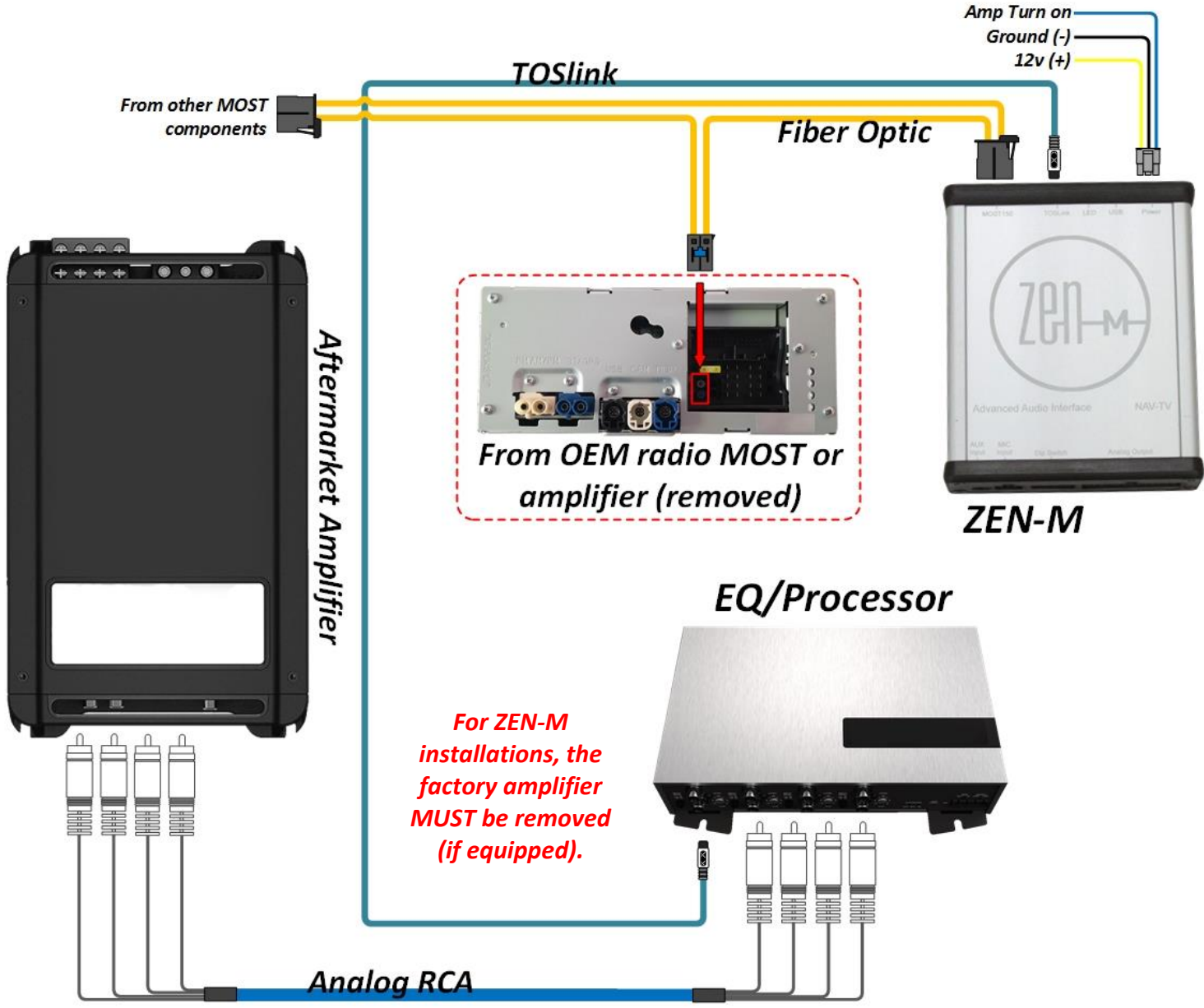

Mercedes Benz options for audio control

When flashing the vehicle for fiber (if not factory fiber or amp-equipped) using the NAV-TV ZEN-M-PRG (KIT866), the OEM Mercedes sound system will allow Bass, Treble and Midrange controls.

- There is no separate subwoofer controller for Mercedes-Benz.

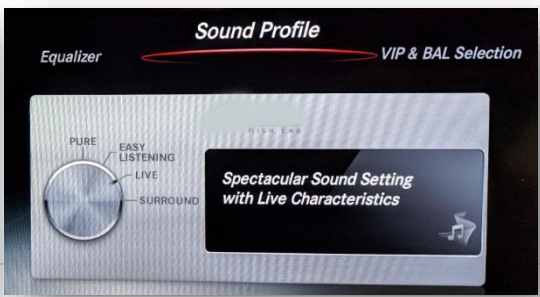

ZEN DownMix Scenario Examples

Source Signal	DownMix	TOSLink Output	Analog FRONT OUT	Analog SIDE OUT (7,8)	Analog REAR OUT (9,10)	Center Channel OUT	SUB OUT
2 Channel (Music)	ON	Stereo	Stereo Front	Stereo Rear	Stereo Rear	Muted	Mono (L+R)
2 Channel (Music)	OFF	Stereo Front	Stereo Front	Stereo Rear	Stereo Rear	Center	Mono (L+R)
5.1 Surround	ON	Mixed Stereo*	Front + Center	Rear + Center	Rear + Center	Muted	Mono (L+R)
5.1 Surround	OFF	Stereo Front	Stereo Front	Rear Back Surround	Rear Back Surround	Center	LFE**
7.1 Surround	ON	Mixed Stereo*	Front + Center	Rear + Center	Rear + Center	Muted	Mono (L+R)
7.1 Surround	OFF	Stereo Front	Stereo Front	Side Surround	Rear Back Surround	Center	LFE**

*Mixed Stereo: (Left = LeftFront + Center + LeftSurround + LFE), (Right = RightFront + Center + RightSurround + LFE)
 **LFE: Low Frequency Effects: Surround subwoofer output.

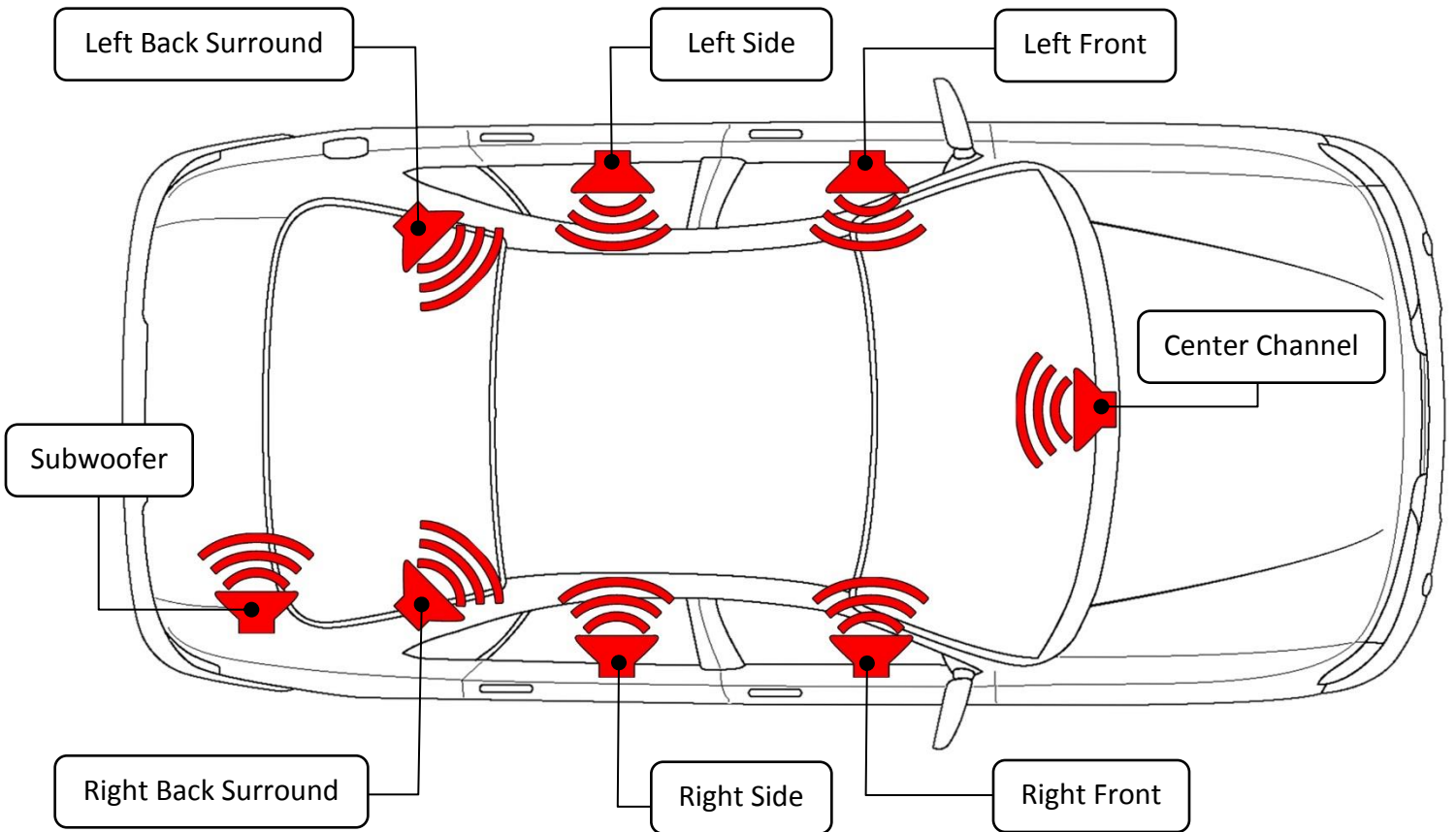

ZEN-M Technical Specifications

<i>Hardware & Software</i>	
Current HW version:	--1r0--
Current SW version:	ZEN-M-1.2-4-20-18
Compatible SW (update) OS:	Windows 7 (64 bit), 8, 10
<i>INPUT</i>	
Digital Input	MOST 150 Fiber Optic
<i>OUTPUT</i>	
Digital Outputs:	TOSLink
Digital Outputs supported:	24bit/48kHz
Frequency Response (digital):	18Hz – 24kHz
Analog Outputs:	12 channels (RCA)
Output Voltage <i>Peak</i> :	6v
Output Voltage <i>RMS</i> :	2.1v
Analog Output Type:	Single-Ended
S/N Ratio (analog):	123dB
Frequency Response (analog):	18Hz – 24kHz
THD+N @ -1dBFS	-94dB
DAC	48kHz 32bit
DSP	32bit Floating Point
Delay (Time Alignment)	Selectable
<i>Power Supply</i>	
Current Consumption Stand-by	<1 mA
Current Consumption Operational	350 mA MAX
Operational Voltage	7V – 20V DC
Amp Turn-On Output	Automatic
Amp Turn-On Voltage	V-batt
Amp Turn-On Current Limitation	500mA
<i>Other</i>	
Dimensions:	4"x5"x1 3/8"
Weight:	10 oz
Country of Origin:	USA

NAV-TV

INTERFACING THE FUTURE

